

Mitsubishi Electric Industrial Robot

CR800 Series Controller

INSTRUCTION MANUAL

Controller setup, basic operation, and maintenance

CR800-D
CR800-R
CR800-Q

Safety Precautions

Always read the following precautions and the separate "Safety Manual" before starting use of the robot to learn the required measures to be taken.

-  **CAUTION** All teaching work must be carried out by an operator who has received special training. (This also applies to maintenance work with the power source turned ON.)
Enforcement of safety training
-  **CAUTION** For teaching work, prepare a work plan related to the methods and procedures of operating the robot, and to the measures to be taken when an error occurs or when restarting. Carry out work following this plan. (This also applies to maintenance work with the power source turned ON.)
Preparation of work plan
-  **WARNING** Prepare a device that allows operation to be stopped immediately during teaching work. (This also applies to maintenance work with the power source turned ON.)
Setting of emergency stop switch
-  **CAUTION** During teaching work, place a sign indicating that teaching work is in progress on the start switch, etc. (This also applies to maintenance work with the power source turned ON.)
Indication of teaching work in progress
-  **DANGER** Provide a fence or enclosure during operation to prevent contact of the operator and robot.
Installation of safety fence
-  **CAUTION** Establish a set signaling method to the related operators for starting work, and follow this method.
Signaling of operation start
-  **CAUTION** As a principle turn the power OFF during maintenance work. Place a sign indicating that maintenance work is in progress on the start switch, etc.
Indication of maintenance work in progress
-  **CAUTION** Before starting work, inspect the robot, emergency stop switch and other related devices, etc., and confirm that there are no errors.
Inspection before starting work

The points of the precautions given in the separate "Safety Manual" are given below. Refer to the actual "Safety Manual" for details.

- ⚠ DANGER** When automatic operation of the robot is performed using multiple control devices (GOT, programmable controller, push-button switch), the interlocking of operation rights of the devices, etc. must be designed by the customer.
- ⚠ CAUTION** Use the robot within the environment given in the specifications. Failure to do so could lead to a drop or reliability or faults. (Temperature, humidity, atmosphere, noise environment, etc.)
- ⚠ CAUTION** Transport the robot with the designated transportation posture. Transporting the robot in a non-designated posture could lead to personal injuries or faults from dropping.
- ⚠ CAUTION** Always use the robot installed on a secure table. Use in an instable posture could lead to positional deviation and vibration.
- ⚠ CAUTION** Wire the cable as far away from noise sources as possible. If placed near a noise source, positional deviation or malfunction could occur.
- ⚠ CAUTION** Do not apply excessive force on the connector or excessively bend the cable. Failure to observe this could lead to contact defects or wire breakage.
- ⚠ CAUTION** Make sure that the workpiece weight, including the hand, does not exceed the rated load or tolerable torque. Exceeding these values could lead to alarms or faults.
- ⚠ WARNING** Securely install the hand and tool, and securely grasp the workpiece. Failure to observe this could lead to personal injuries or damage if the object comes off or flies off during operation.
- ⚠ WARNING** Securely ground the robot and controller. Failure to observe this could lead to malfunctioning by noise or to electric shock accidents.
- ⚠ CAUTION** Indicate the operation state during robot operation. Failure to indicate the state could lead to operators approaching the robot or to incorrect operation.
- ⚠ WARNING** When carrying out teaching work in the robot's movement range, always secure the priority right for the robot control. Failure to observe this could lead to personal injuries or damage if the robot is started with external commands.
- ⚠ CAUTION** Keep the jog speed as low as possible, and always watch the robot. Failure to do so could lead to interference with the workpiece or peripheral devices.
- ⚠ CAUTION** After editing the program, always confirm the operation with step operation before starting automatic operation. Failure to do so could lead to interference with peripheral devices because of programming mistakes, etc.
- ⚠ CAUTION** Make sure that if the safety fence entrance door is opened during automatic operation, the door is locked or that the robot will automatically stop. Failure to do so could lead to personal injuries.
- ⚠ CAUTION** Never carry out modifications based on personal judgments, or use non-designated maintenance parts. Failure to observe this could lead to faults or failures.

 **WARNING**

When the robot arm has to be moved by hand from an external area, do not place hands or fingers in the openings. Failure to observe this could lead to hands or fingers catching depending on the posture.

 **CAUTION**

Do not stop the robot or apply emergency stop by turning the robot controller's main power OFF. If the robot controller main power is turned OFF during automatic operation, the robot accuracy could be adversely affected. Moreover, it may interfere with the peripheral device by drop or move by inertia of the arm.

 **CAUTION**

Do not turn off the main power to the robot controller while rewriting the internal information of the robot controller such as the program or parameters. If the main power to the robot controller is turned off while in automatic operation or rewriting the program or parameters, the internal information of the robot controller may be damaged.

 **DANGER**

Do not connect the Handy GOT when using the GOT direct connection function of this product. Failure to observe this may result in property damage or bodily injury because the Handy GOT can automatically operate the robot regardless of whether the operation rights are enabled or not.

 **DANGER**

Do not connect the Handy GOT to a programmable controller when using an iQ Platform compatible product with the CR800-R/CR800-Q controller. Failure to observe this may result in property damage or bodily injury because the Handy GOT can automatically operate the robot regardless of whether the operation rights are enabled or not.

 **DANGER**

Do not remove the SSCNET III cable while power is supplied to the multiple CPU system or the servo amplifier. Do not look directly at light emitted from the tip of SSCNET III connectors or SSCNET III cables of the Motion CPU or the servo amplifier. Eye discomfort may be felt if exposed to the light. (Reference: SSCNET III employs a Class 1 or equivalent light source as specified in JIS C 6802 and IEC60825-1 (domestic standards in Japan).)

 **DANGER**

Do not remove the SSCNET III cable while power is supplied to the controller. Do not look directly at light emitted from the tip of SSCNET III connectors or SSCNET III cables. Eye discomfort may be felt if exposed to the light. (Reference: SSCNET III employs a Class 1 or equivalent light source as specified in JIS C 6802 and IEC60825-1 (domestic standards in Japan).)

 **DANGER**

Attach the cap to the SSCNET III connector after disconnecting the SSCNET III cable. If the cap is not attached, dirt or dust may adhere to the connector pins, resulting in deterioration connector properties, and leading to malfunction.

 **CAUTION**

Make sure there are no mistakes in the wiring. Connecting differently to the way specified in the manual can result in errors, such as the emergency stop not being released. In order to prevent errors occurring, please be sure to check that all functions (such as the teaching box emergency stop, customer emergency stop, and door switch) are working properly after the wiring setup is completed.

CAUTION

Use the network equipments (personal computer, USB hub, LAN hub, etc) confirmed by manufacturer. The thing unsuitable for the FA environment (related with conformity, temperature or noise) exists in the equipments connected to USB. When using network equipment, measures against the noise, such as measures against EMI and the addition of the ferrite core, may be necessary. Please fully confirm the operation by customer. Guarantee and maintenance of the equipment on the market (usual office automation equipment) cannot be performed.

CAUTION

To maintain the security (confidentiality, integrity, and availability) of the robot and the system against unauthorized access, DoS*¹ attacks, computer viruses, and other cyberattacks from unreliable networks and devices via network, take appropriate measures such as firewalls, virtual private networks (VPNs), and antivirus solutions.

Mitsubishi Electric shall have no responsibility or liability for any problems involving robot trouble and system trouble by unauthorized access, DoS attacks, computer viruses, and other cyberattacks.

*1 DoS: A denial-of-service (DoS) attack disrupts services by overloading systems or exploiting vulnerabilities, resulting in a denial-of-service (DoS) state.

*CR800 controller

Notes of the basic component are shown.

⚠ CAUTION Please install the earth leakage breaker in the primary side power supply of the controller because of leakage protection.

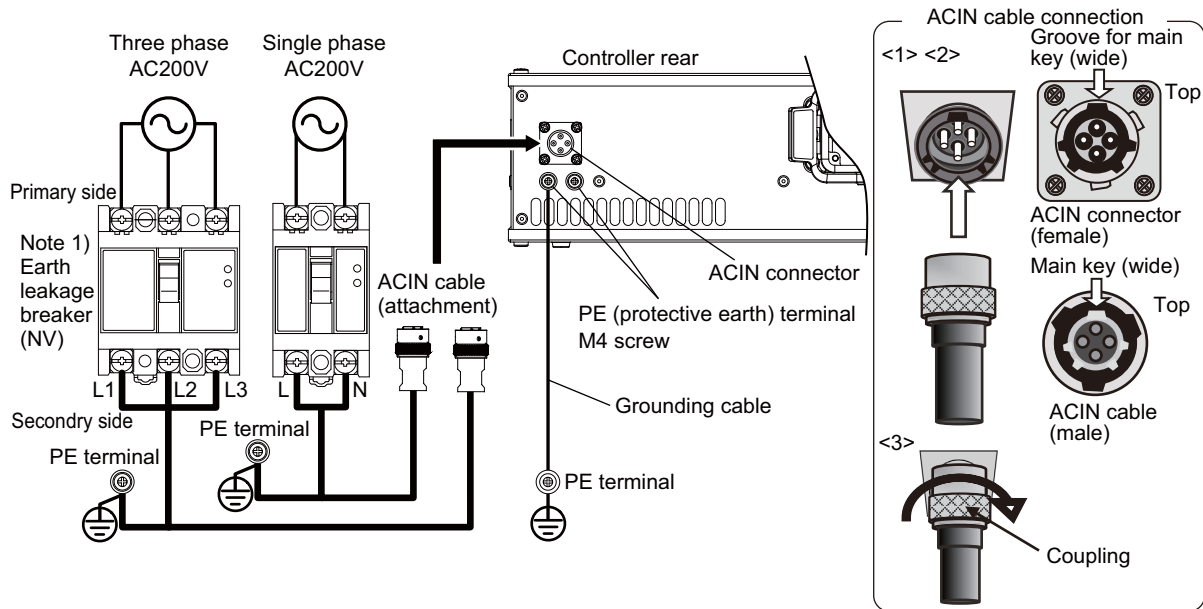

Note 1) Always use the terminal cover for the earth leakage breaker.

1) Prepare the following items.

Part name	Specifications	Remarks
Earth leakage breaker	The following is recommended product. Single phase: NV30FAU-2P-10A-AC100-240V-30mA (Terminal cover: TCS-05FA2) Three phase: NV30FAU-3P-10A-AC100-240V-30mA (Terminal cover: TCS-05FA3)	Prepared by customer.
Cable for primary power supply	AWG14 (2mm ²) or above	Prepared by customer. Tightening torque for terminal fixing screw is 2 ~ 3Nm.
Grounding cable	AWG14 (2mm ²) or above	Prepared by customer. Tightening torque for terminal fixing screw is 2 ~ 3Nm.
ACIN cable	Terminal: M5, cable length: 3m	Supplied with the product.

- 2) Confirm that the primary power matches the specifications.
- 3) Confirm that the primary power is OFF and that the earth leakage breaker power switch is OFF.
- 4) Connect the ACIN cable to the breaker.
Connect the power terminals of the ACIN cable to the secondary side terminals of the earth leakage breaker. Also, ground the FG terminal of the cable.
- 5) Connect the ACIN cable to the ACIN connector on the rear of the controller.
 - <1> Face the main key on the ACIN cable plug upwards. (Refer to the "ACIN cable connection" illustration.)
 - <2> Align the main key of the ACIN cable plug with the grooves on the ACIN connector. Push the plug into the connector as far as it will go.
The plug may be damaged if it is not correctly aligned with the connector.
 - <3> Tighten the coupling on the ACIN cable, turning it to the right until it locks.
- 6) Connect one end of the grounding cable to the PE (protective earth) terminal on the controller and ground the other end (2-point grounding) in order to comply with the requirements of EN 61800-5-1 for the touch current of 3.5 mA AC or more.
- 7) Connect the primary power cable to the primary side terminal of the earth leakage breaker.

Revision history

Date of print	Specifications No.	Details of revisions
2017-04-25	BFP-A3476	<ul style="list-style-type: none"> • First print
2017-09-25	BFP-A3476-A	<ul style="list-style-type: none"> • "4.3.2 Input the serial number" was added.
2017-11-01	BFP-A3476-B	<ul style="list-style-type: none"> • Description of countermeasures against unauthorized access was added. • Descriptions of CR800-R controller in "4.1.1 Names of each parts" were supplemented.
2018-03-01	BFP-A3476-C	<ul style="list-style-type: none"> • Descriptions of CR800-Q controller were added.
2018-09-01	BFP-A3476-D	<ul style="list-style-type: none"> • "3.1 Installing/removing the Option Card" was modified.
2018-12-25	BFP-A3476-E	<ul style="list-style-type: none"> • Added further explanation of the ACIN cable. • "2.3.8 Magnet contactor control connector output (AXMC) for addition axes" was modified.
2019-04-19	BFP-A3476-F	<ul style="list-style-type: none"> • Description of connectors (EXT1, OPT1, OPT2) was corrected.
2019-07-18	BFP-A3476-G	<ul style="list-style-type: none"> • Correction of figures. (Fig. 2-8, 14)
2020-10-30	BFP-A3476-H	<ul style="list-style-type: none"> • Amended the precautions regarding the prevention of unauthorized access. • Added an example of a protective circuit. (Fig. 2-7) • Added precautions for vertical installation of the robot controller. • Revised the steps for replacing the battery. • Corrected other mistakes and changed some sections.

■ Introduction

Thank you for purchasing the Mitsubishi industrial robot.

This instruction manual explains the unpacking methods, installation, basic operation, maintenance and inspection of the controller.

Always read through this manual before starting use to ensure correct usage of the robot.

The optional equipments and power supply voltage are different according to connecting robot type.

Refer to separate "Standard Specifications Manual" for detail.

The information contained in this document has been written to be accurate as much as possible. Please interpret that items not described in this document "cannot be performed."

This document explains for CR800 series controller.

Installation of the emergency stop switch

To be able to stop the robot immediately at the time of the abnormalities because of safety, please install the emergency stop switch in the position which is certainly easy to operate it, and connect with the controller. Refer to the [Page 25, "2.3.6 Connecting the external emergency stop and mode selector switch"](#) for the connection method.

And, the connection method of the door switch or the mode selector switch is also indicated here. Please use it together with the emergency stop switch.

Synchronous connection of the addition axis servo power supply

It is building the circuit so that the output point of contact (additional axis synchronization output: AXMC) installed in the controller may be used in use of the addition axis function and the power supply of the servo amplifier for addition axes may be shut down by opening of this output. The servo ON/OFF state of the addition axis can be synchronized with the servo ON/OFF state of the robot arm. With reference to [Page 36, "2.3.8 Additional axis synchronization output"](#), I ask you to have synchronous connection made.

Notice

- *ONLY QUALIFIED SERVICE PERSONNEL MAY INSTALL OR SERVICE THE ROBOT SYSTEM.
- *ANY PERSON WHO PROGRAM, TEACHES, OPERATE, MAINTENANCE OR REPAIRS THE ROBOT SYSTEM IS TRAINED AND DEMONSTRATES COMPETENCE TO SAFELY PERFORM THE ASSIGNED TASK.
- *ENSURE COMPLIANCE WITH ALL LOCAL AND NATIONAL SAFETY AND ELECTRICAL CODES FOR THE INSTALLATION AND OPERATION OF THE ROBOT SYSTEM.

- No part of this manual may be reproduced by any means or in any form, without prior consent from Mitsubishi.
- The details of this manual are subject to change without notice.
- The information contained in this document has been written to be accurate as much as possible. Please interpret that items not described in this document "cannot be performed." or "alarm may occur".
- Please contact your nearest dealer if you find any doubtful, wrong or skipped point.
- This is the original document.
- Company names and production names in this document are the trademarks or registered trademarks of their respective owners.
- Illustrations in this Instruction Manual may differ from the actual products.

For users operating robots that have not been mounted with an operation panel:

Operation of robot programs such as start-up and shutdown are carried out using external signals (exclusive input/output signals). This instruction manual is based on key operations on the teaching pendant and operation in the operation screen of the teaching pendant. Using the parameter settings, please assign exclusive input/output signals that correspond with each operation to general purpose input/output signals, and operate the robot using signal operations.

The following table details exclusive input/output signals that correspond with the key operations of the operation panel explained in this manual. Please use this as a reference to assign signals and operate the robot.

For further details regarding parameters please see the separate instruction manual "Detailed explanations of functions and operations".

Table: Dedicated I/O signals corresponding to the teaching pendant (T/B) operations

T/B operation	Parameter name	Class	Function	Default setting
Start In operation	START	Input	Starts a program.	3,0
		Output	Indicates that a program is being executed.	
[STOP] key Standby	STOP	Input	Stops a program.	0,-1
		Output	Indicates that the program is paused.	
[RESET] key ERROR lamp Program reset	ERRRESET	Input	Releases the error state.	2,2
		Output	Indicates that an error has occurred.	
	SLOTINIT	Input	Cancels the paused status of the program and brings the executing line to the top. Executing a program reset makes it possible to select a program.	-1,-1
		Output	Outputs that in the program selection enabled state.	
Program selection [OVRD ↑] key [OVRD ↓] key Step display	PRGSEL	Input	Selects the value inputted into the signal assigned to the numerical input as a program number.	-1,
		Output	-	
	PRGOUT	Input	Outputs the program number selected to the signal assigned to the numerical output.	-1,-1
		Output	Indicates outputting the program number to the numerical output.	
	OVRDSEL	Input	Sets the value inputted into the signal assigned to the numerical input as an override.	-1,
		Output	-	
	OVRDOUT	Input	Outputs the override value to the signal assigned to the numerical output.	-1,-1
		Output	Indicates outputting the override value to the numerical output.	
	LINEOUT	Input	Outputs the current line number to the signal assigned to the numerical output.	-1,-1
		Output	Indicates outputting the current line number to the numerical output.	
	ERRROUT	Input	Outputs the error number to the signal assigned to the numerical output.	-1,-1
		Output	Indicates outputting the error number to the numerical output.	
	IODATA	Input	Reads the program number and the override value as a binary value.	-1,-1, -1,-1
		Output	Outputs the program number, line number and override value as a binary value.	
Continuous Cycle	CYCLE	Input	Starts the cycle stop.	-1,-1
		Output	Outputs that the cycle stop is operating.	
[SERVO] key SERVO lamp	SRVON	Input	Turns ON the servo power supply.	4,1
		Output	Indicates the servo power supply is ON.	
[SERVO] key SERVO lamp	SRVOFF	Input	Turns OFF the servo power supply.	1,-1
		Output	This output indicates a status where the servo power supply cannot be turned ON. (Echo back)	

Contents

	Page
1 Before starting use	1-1
1.1 Using the instruction manuals	1-1
1.1.1 The details of each instruction manuals	1-1
1.1.2 Symbols used in instruction manual	1-2
1.2 Safety Precautions	1-3
1.2.1 Precautions given in the separate Safety Manual	1-4
2 Unpacking to installation	2-6
2.1 Confirming the products	2-6
2.2 Installation	2-7
2.2.1 Unpacking procedures	2-7
2.2.2 Transportation procedures	2-7
2.2.3 Installation procedures	2-8
2.3 Installation and connection	2-10
2.3.1 Installation of the robot CPU unit (CR800-R controller)	2-10
(1) Notes on the handling	2-10
(2) Notes on base unit installation	2-12
(3) Installation and removal of the unit	2-14
2.3.2 Installation of the robot CPU unit (CR800-Q controller)	2-16
(1) Notes on the handling	2-16
(2) Notes on base unit installation	2-18
(3) Installation and removal of the unit	2-20
2.3.3 Connecting the power cable and grounding cable	2-22
2.3.4 Connection between the robot CPU unit and the drive unit	2-23
2.3.5 Emergency stop input and output etc.	2-24
2.3.6 Connecting the external emergency stop and mode selector switch	2-25
2.3.7 Examples of safety measures	2-31
(1) External emergency stop connection [supplementary explanation]	2-35
2.3.8 Additional axis synchronization output	2-36
(1) Example circuit	2-36
(2) Image of how to connect the controller connector	2-37
2.3.9 Connecting to the robot arm	2-38
(1) Connecting a machine cable	2-38
(2) Removing a machine cable	2-38
2.4 Confirming the operation	2-38
3 Installing the option devices	3-39
3.1 Installing/removing the Option Card	3-39
3.1.1 Installing the Option Card	3-39
3.1.2 Removing the Option Card	3-40
3.2 Installing and wiring of the controller protection box (CR800-MB)	3-41
4 Basic operations	4-43
4.1 Handling the controller	4-44
4.1.1 Names of each parts	4-44
4.2 Handling the T/B	4-47
4.2.1 Installing and removing the T/B	4-47
(1) Installing the T/B	4-47
(2) Removing the T/B	4-47
4.2.2 Functions of each key	4-48
4.3 Turning the power ON and OFF	4-49
4.3.1 Turning the control power ON	4-49
4.3.2 Input the serial number	4-50
4.3.3 Shutting OFF the control power	4-51
4.3.4 Shutting OFF the controller power	4-52
4.4 Jog operation	4-53

Contents

	Page
4.5 Opening and closing the hand	4-54
4.6 Programming	4-55
(1) Creation procedures	4-55
(2) Robot work	4-55
4.6.1 Creating the program	4-56
(1) Deciding the operation order	4-56
(2) Deciding the operation position name	4-57
(3) Describing and creating the program	4-58
(4) Confirming the program	4-64
(5) Correcting the program	4-65
(6) Saving the program	4-68
(7) Start automatic operation.	4-69
5 Maintenance and Inspection	5-73
5.1 Maintenance and inspection interval	5-73
5.2 Inspection items	5-74
5.2.1 Daily inspection items	5-74
5.2.2 Periodic inspections	5-74
5.3 Maintenance and inspection procedures	5-75
5.3.1 Replacing the battery (CR800-Q controller only)	5-75
5.3.2 The check of the filter, cleaning, exchange.	5-77
5.4 Maintenance parts	5-78

1 Before starting use

This chapter explains the details and usage methods of the instruction manuals, the basic terminology and the safety precautions. Moreover, handling and operation of a teaching pendant (T/B) are described based on R32TB in instruction manuals. If using other T/B, such as R56TB, refer to a supplied instruction manual of the T/B.

1.1 Using the instruction manuals

1.1.1 The details of each instruction manuals

The contents and purposes of the documents enclosed with this product are shown below. Use these documents according to the application.



For special specifications, a separate instruction manual describing the special section may be enclosed.

Manual name	Description
Safety Manual	Explains the common precautions and safety measures to be taken for robot handling, system design and manufacture to ensure safety of the operators involved with the robot.
Standard Specifications	Explains the product's standard specifications, factory-set special specifications, option configuration and maintenance parts, etc. Precautions for safety and technology, when incorporating the robot, are also explained.
Robot Arm Setup & Maintenance	Explains the procedures required to operate the robot arm (unpacking, transportation, installation, confirmation of operation), and the maintenance and inspection procedures.
Controller setup, basic operation, and maintenance	Explains the procedures required to operate the controller (unpacking, transportation, installation, confirmation of operation), basic operation from creating the program to automatic operation, and the maintenance and inspection procedures.
Detailed explanations of functions and operations	Explains details on the functions and operations such as each function and operation, commands used in the program, connection with the external input/output device, and parameters, etc.
Troubleshooting	Explains the causes and remedies to be taken when an error occurs. Explanations are given for each error No.
Additional axis function	Explains the specifications, functions and operations of the additional axis control.
Tracking Function	Explains the control function and specifications of conveyor tracking.
GOT Direct Connection Extended Function	Explains the detailed description of data configuration of shared memory, monitoring, and operating procedures about the GOT (standalone type robot).
iQ Platform Supporting Extended Function	Explains the detailed description of data configuration of shared memory, monitoring, and operating procedures about the PLC (iQ Platform compatible type robot).
Ethernet Function	Explains the measures to perform communication with personal computers on Ethernet with the TCP/IP protocol.

1.1.2 Symbols used in instruction manual

The symbols and expressions shown in [Table 1-1](#) are used throughout this instruction manual. Learn the meaning of these symbols before reading this instruction manual.

Table 1-1: Symbols in instruction manual

Terminology	Item/Symbol	Meaning
Item	iQ Platform compatible type	
	Controller	Indicates the controller which controls the robot arm.
	The robot CPU unit or robot CPU	Indicates the CPU unit for the robots which installed to the sequencer base unit of MELSEC iQ-R/MELSEC-Q series. It is connected with the controller by the dedicated cable.
	The robot CPU system	Multi-CPU system. It consists of MELSEC units, such as the sequencer base unit, the sequencer CPU unit, and the robot CPU unit, etc.
	Standalone type	
	Controller	Indicates the controller which controls the robot arm.
Symbol	 DANGER	Precaution indicating cases where there is a risk of operator fatality or serious injury if handling is mistaken. Always observe these precautions to safely use the robot.
	 WARNING	Precaution indicating cases where the operator could be subject to fatalities or serious injuries if handling is mistaken. Always observe these precautions to safely use the robot.
	 CAUTION	Precaution indicating cases where operator could be subject to injury or physical damage could occur if handling is mistaken. Always observe these precautions to safely use the robot.
	[JOG]	If a word is enclosed in brackets or a box in the text, this refers to a key on the teaching pendant.
	[RESET] + [EXE] (A) (B)	This indicates to press the (B) key while holding down the (A) key. In this example, the [RESET] key is pressed while holding down the [EXE] key.
	T/B	This indicates the teaching pendant. Descriptions in this manual are based on R32TB.

1.2 Safety Precautions

Always read the following precautions and the separate "Safety Manual" before starting use of the robot to learn the required measures to be taken.

- ⚠ CAUTION** All teaching work must be carried out by an operator who has received special training. (This also applies to maintenance work with the power source turned ON.)
Enforcement of safety training
- ⚠ CAUTION** For teaching work, prepare a work plan related to the methods and procedures of operating the robot, and to the measures to be taken when an error occurs or when restarting. Carry out work following this plan. (This also applies to maintenance work with the power source turned ON.)
Preparation of work plan
- ⚠ WARNING** Prepare a device that allows operation to be stopped immediately during teaching work. (This also applies to maintenance work with the power source turned ON.)
Setting of emergency stop switch
- ⚠ CAUTION** During teaching work, place a sign indicating that teaching work is in progress on the start switch, etc. (This also applies to maintenance work with the power source turned ON.)
Indication of teaching work in progress
- ⚠ DANGER** Provide a fence or enclosure during operation to prevent contact of the operator and robot.
Installation of safety fence
- ⚠ CAUTION** Establish a set signaling method to the related operators for starting work, and follow this method.
Signaling of operation start
- ⚠ CAUTION** As a principle turn the power OFF during maintenance work. Place a sign indicating that maintenance work is in progress on the start switch, etc.
Indication of maintenance work in progress
- ⚠ CAUTION** Before starting work, inspect the robot, emergency stop switch and other related devices, etc., and confirm that there are no errors.
Inspection before starting work

1.2.1 Precautions given in the separate Safety Manual

The points of the precautions given in the separate "Safety Manual" are given below. Refer to the actual "Safety Manual" for details.

 **DANGER**

When automatic operation of the robot is performed using multiple control devices (GOT, programmable controller, push-button switch), the interlocking of operation rights of the devices, etc. must be designed by the customer.

 **CAUTION**

Use the robot within the environment given in the specifications. Failure to do so could lead to a drop or reliability or faults. (Temperature, humidity, atmosphere, noise environment, etc.)

 **CAUTION**

Transport the robot with the designated transportation posture. Transporting the robot in a non-designated posture could lead to personal injuries or faults from dropping.

 **CAUTION**

Always use the robot installed on a secure table. Use in an instable posture could lead to positional deviation and vibration.

 **CAUTION**

Wire the cable as far away from noise sources as possible. If placed near a noise source, positional deviation or malfunction could occur.

 **CAUTION**

Do not apply excessive force on the connector or excessively bend the cable. Failure to observe this could lead to contact defects or wire breakage.

 **CAUTION**

Make sure that the workpiece weight, including the hand, does not exceed the rated load or tolerable torque. Exceeding these values could lead to alarms or faults.

 **WARNING**

Securely install the hand and tool, and securely grasp the workpiece. Failure to observe this could lead to personal injuries or damage if the object comes off or flies off during operation.

 **WARNING**

Securely ground the robot and controller. Failure to observe this could lead to malfunctioning by noise or to electric shock accidents.

 **CAUTION**

Indicate the operation state during robot operation. Failure to indicate the state could lead to operators approaching the robot or to incorrect operation.

 **WARNING**

When carrying out teaching work in the robot's movement range, always secure the priority right for the robot control. Failure to observe this could lead to personal injuries or damage if the robot is started with external commands.

 **CAUTION**

Keep the jog speed as low as possible, and always watch the robot. Failure to do so could lead to interference with the workpiece or peripheral devices.

 **CAUTION**

After editing the program, always confirm the operation with step operation before starting automatic operation. Failure to do so could lead to interference with peripheral devices because of programming mistakes, etc.

 **CAUTION**

Make sure that if the safety fence entrance door is opened during automatic operation, the door is locked or that the robot will automatically stop. Failure to do so could lead to personal injuries.

 **CAUTION**

Never carry out modifications based on personal judgments, or use non-designated maintenance parts. Failure to observe this could lead to faults or failures.

 **WARNING**

When the robot arm has to be moved by hand from an external area, do not place hands or fingers in the openings. Failure to observe this could lead to hands or fingers catching depending on the posture.

⚠ CAUTION

Do not stop the robot or apply emergency stop by turning the robot controller's main power OFF.
If the robot controller main power is turned OFF during automatic operation, the robot accuracy could be adversely affected.

⚠ CAUTION

Do not turn off the main power to the robot controller while rewriting the internal information of the robot controller such as the program or parameters. If the main power to the robot controller is turned off while in automatic operation or rewriting the program or parameters, the internal information of the robot controller may be damaged.

⚠ CAUTION

Do not connect the Handy GOT when using the GOT direct connection function of this product. Failure to observe this may result in property damage or bodily injury because the Handy GOT can automatically operate the robot regardless of whether the operation rights are enabled or not.

⚠ DANGER

Do not connect the Handy GOT to a programmable controller when using an iQ Platform compatible product with the CR800-R/CR800-Q controller. Failure to observe this may result in property damage or bodily injury because the Handy GOT can automatically operate the robot regardless of whether the operation rights are enabled or not.

⚠ DANGER

Do not remove the SSCNET III cable while power is supplied to the multiple CPU system or the servo amplifier. Do not look directly at light emitted from the tip of SSCNET III connectors or SSCNET III cables of the Motion CPU or the servo amplifier. Eye discomfort may be felt if exposed to the light. (Reference: SSCNET III employs a Class 1 or equivalent light source as specified in JIS C 6802 and IEC60825-1 (domestic standards in Japan).)

⚠ DANGER

Do not remove the SSCNET III cable while power is supplied to the controller. Do not look directly at light emitted from the tip of SSCNET III connectors or SSCNET III cables. Eye discomfort may be felt if exposed to the light. (Reference: SSCNET III employs a Class 1 or equivalent light source as specified in JIS C 6802 and IEC60825-1 (domestic standards in Japan).)

⚠ DANGER

Attach the cap to the SSCNET III connector after disconnecting the SSCNET III cable. If the cap is not attached, dirt or dust may adhere to the connector pins, resulting in deterioration connector properties, and leading to malfunction.

⚠ CAUTION

Make sure there are no mistakes in the wiring. Connecting differently to the way specified in the manual can result in failures, such as the emergency stop not being released. In order to prevent from occurring, please be sure to check that all functions (such as the teaching box emergency stop, customer emergency stop, and door switch) are working properly after the wiring setup is completed

⚠ CAUTION

Use the network equipments (personal computer, USB hub, LAN hub, etc) confirmed by manufacturer. The thing unsuitable for the FA environment (related with conformity, temperature or noise) exists in the equipments connected to USB. When using network equipment, measures against the noise, such as measures against EMI and the addition of the ferrite core, may be necessary. Please fully confirm the operation by customer. Guarantee and maintenance of the equipment on the market (usual office automation equipment) cannot be performed.

⚠ CAUTION

To maintain the security (confidentiality, integrity, and availability) of the robot and the system against unauthorized access, DoS^{*1} attacks, computer viruses, and other cyberattacks from unreliable networks and devices via network, take appropriate measures such as firewalls, virtual private networks (VPNs), and antivirus solutions.

Mitsubishi Electric shall have no responsibility or liability for any problems involving robot trouble and system trouble by unauthorized access, DoS attacks, computer viruses, and other cyberattacks.

*1 DoS: A denial-of-service (DoS) attack disrupts services by overloading systems or exploiting vulnerabilities, resulting in a denial-of-service (DoS) state.

2 Unpacking to installation

2.1 Confirming the products

Confirm that the parts shown in the standard configuration of the controller shown in [Table 2-1](#) are enclosed with the purchased product.

Users who have purchased options should refer to the separate "Standard Specifications". The primary power supply cable and grounding cable must be prepared by the customer.

Table 2-1 : Standard configuration

No.	Part name	Type	Qty.	Remarks
CR800-D controller				
1	Controller	CR800-D	1 unit	Stand alone type
2	CD-ROM (Instruction manual)	5F-GA01-C00	1 pc.	
3	ACIN cable	BKO-FA1006H53	1 pc.	Accessory cable for single phase. The cable is 3m in length.
		BKO-FA1006H03	1 pc.	Accessory cable for single phase and three phase. The cable is 3m in length.
4	CNUSR11 connector	DFMC-1.5-16-ST-3.5-LR	1 pc.	Manufactured by PHOENIX CONTACT
5	CNUSR12 connector	DFMC-1.5-9-ST-3.5-LR	1 pc.	Manufactured by PHOENIX CONTACT
6	1.6A fuse (reserves)	LM16	1 pc.	
7	EU DECLARATION OF CONFORMITY	BFP-A5735-29	1 copy	
8	QUICK SETUP GUIDE	BFP-A3548	1 copy	
CR800-R controller				
1	Controller	CR800-R	1 unit	MELSEC iQ-R compatible type
2	Robot CPU unit	R16RTCPU	1 unit	
3	Robot CPU unit connecting cable (SSCNET III cable)	MR-J3BUS10M-A	1 pc.	The cable is 10m length.
4	CD-ROM (Instruction manual)	5F-GA01-C00	1 pc.	
5	ACIN cable	BKO-FA1006H53	1 pc.	Accessory cable for single phase. The cable is 3m in length.
		BKO-FA1006H03	1 pc.	Accessory cable for single phase and three phase. The cable is 3m in length.
6	CNUSR11 connector	DFMC-1.5-16-ST-3.5-LR	1 pc.	Manufactured by PHOENIX CONTACT
7	CNUSR12 connector	DFMC-1.5-9-ST-3.5-LR	1 pc.	Manufactured by PHOENIX CONTACT
8	1.6A fuse (reserves)	LM16	1 pc.	
9	EU DECLARATION OF CONFORMITY	BFP-A5735-29	1 copy	
10	QUICK SETUP GUIDE	BFP-A3548	1 copy	
CR800-Q controller				
1	Controller	CR800-Q	1 unit	MELSEC-Q compatible type
2	Robot CPU unit	Q172DSRCPU	1 unit	
3	Robot CPU unit connecting cable (SSCNET III cable)	MR-J3BUS10M-A	1 pc.	The cable is 10m length.
4	CD-ROM (Instruction manual)	5F-GA01-C00	1 pc.	
5	ACIN cable	BKO-FA1006H53	1 pc.	Accessory cable for single phase. The cable is 3m in length.
		BKO-FA1006H03	1 pc.	Accessory cable for single phase and three phase. The cable is 3m in length.
6	CNUSR11 connector	DFMC-1.5-16-ST-3.5-LR	1 pc.	Manufactured by PHOENIX CONTACT
7	CNUSR12 connector	DFMC-1.5-9-ST-3.5-LR	1 pc.	Manufactured by PHOENIX CONTACT
8	1.6A fuse (reserves)	LM16	1 pc.	
9	EU DECLARATION OF CONFORMITY	BFP-A5735-29	1 copy	
10	QUICK SETUP GUIDE	BFP-A3548	1 copy	

2.2 Installation

2.2.1 Unpacking procedures

The controller is shipped from the factory packaged in cardboard. Open the cardboard package and take out the controller.

2.2.2 Transportation procedures

The following shows how to transport the controller.

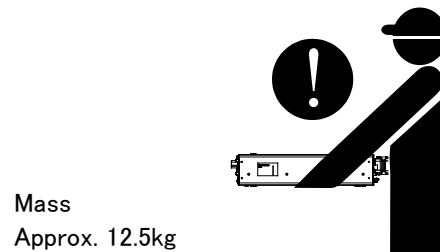

Fig. 2-1 : Transporting controller

- 1) Slightly tilt the controller and put your hands underneath. Providing steady support with both hands, lift it up and transport.
Be careful not to trap fingers when transporting the controller.

2.2.3 Installation procedures

The installed size is shown as follows.

When installing the controller horizontally, only one controller can be stacked on top of another controller.

Horizontal installation

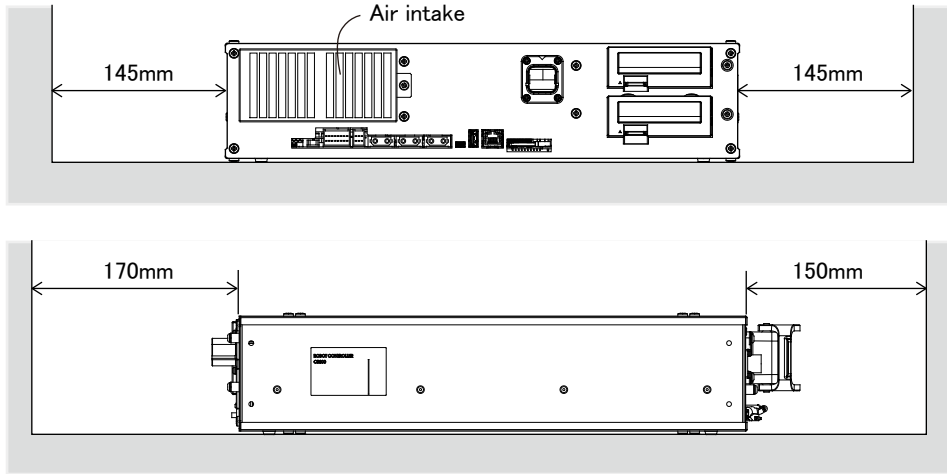

Vertical installation

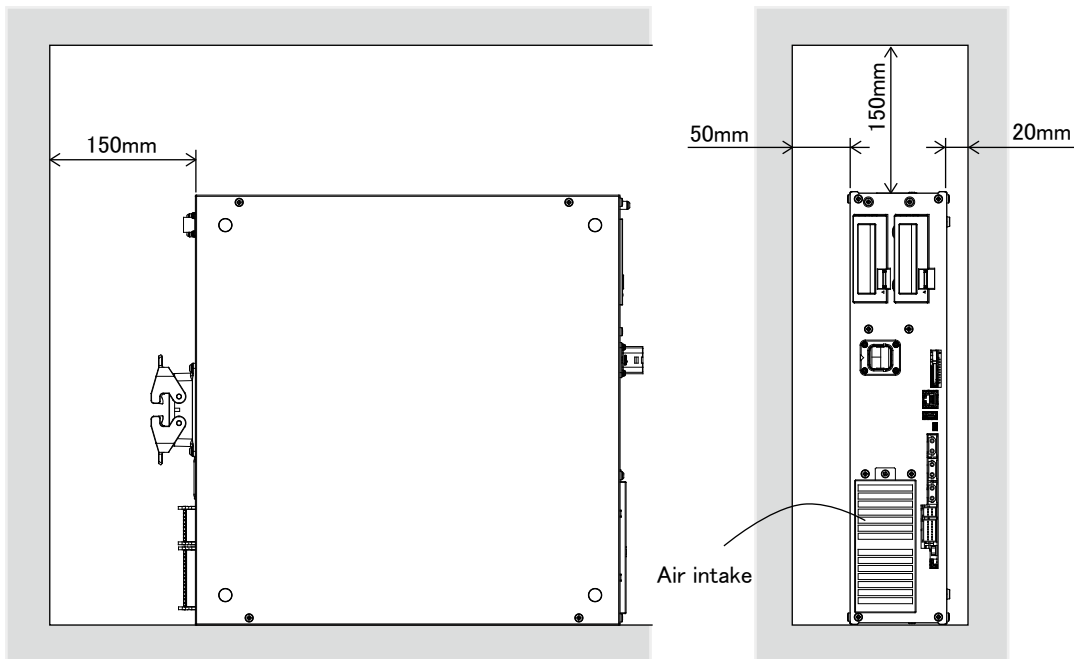

Fig.2-2 : Installation dimensions

CAUTION

When installing the controller vertically, ensure that the air intake is at the bottom as illustrated in Fig. 2-2.

CAUTION

Fixing installation section sure for prevention from the fall, when using the controller placing vertically. The reference figure of the metal plate for fixing is shown in Fig. 2-3. You should install the metal plate for fixation to the controller with M4 x 8 or the shorter screw. The screw projection length inside the controller (side board thickness is 1.2 mm) surely makes 6.8 mm or less.

⚠ CAUTION

When storing the controller in a cabinet, etc., take special care to the heat radiating properties and ventilation properties so that the ambient temperature remains within the specification values. And, don't install the controller in the position where direct rays or the heat of lighting hits. The skin temperature of the controller may rise, and the error may occur.

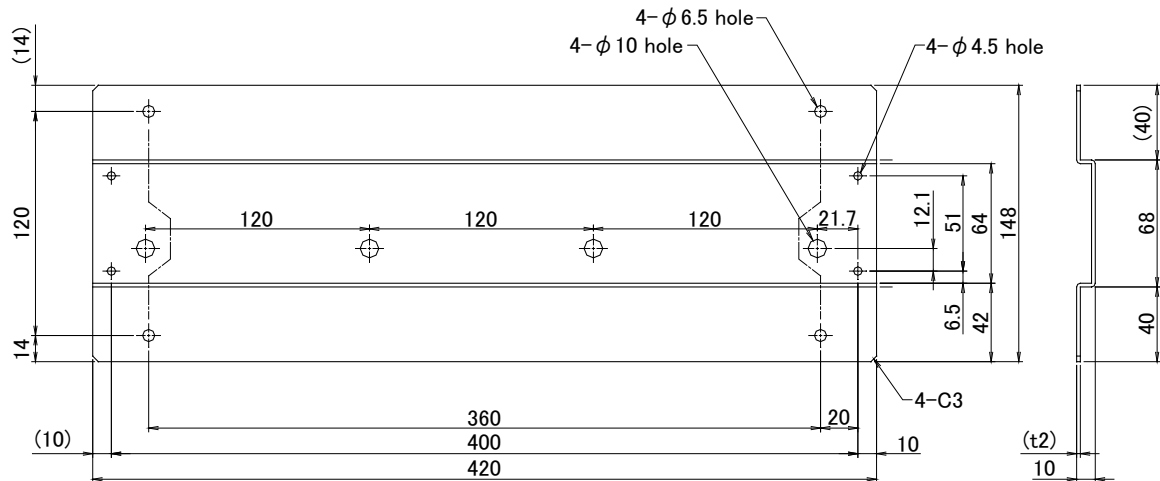

Fig.2-3 : Metal plate for fixation to placing vertically

2.3 Installation and connection

2.3.1 Installation of the robot CPU unit (CR800-R controller)

(1) Notes on the handling

Explain notes on the handling of the CPU unit, the input/output unit, the intelligent functional unit, the power supply unit, the base unit, etc.

- 1) Please do not drop the unit, the terminal stand connector, and the pin connector, or do not supply a strong shock.
- 2) The printed circuit board of the unit should not remove from the case. It becomes the cause of failure.
- 3) Please carry out bolting of the unit fixing screw and the terminal stand screw in the range shown in the table below.

Screw	Bolting torque range [N · m]
Unit fixing screw (M3x12)	0.36 ~ 0.48
Input/output unit terminal stand screw (M3)	0.42 ~ 0.58
Input/output unit terminal stand attachment screw (M3.5)	0.68 ~ 0.92
Terminal screw of the power supply unit (M4)	1.02 ~ 1.38
Terminal screw of the power supply unit (M3.5)	0.66 ~ 0.89

- 4) The basic base unit should equip with the power supply unit at any cost. If the load of the input/output unit and intelligent functional unit with which the base unit is equipped is low, it may operate, even if there is no power supply unit. However, since voltage becomes unstable, operation cannot be guaranteed.
- 5) Since it may malfunction by vibration if it installs the basic base unit in the plate, please be sure to fix with the screw for fixing.

CAUTION

- 1) Please use the robot CPU system in the environment of general specification given in this manual. If other, it becomes the electric shock, the fire, malfunction, the damage to the product, or the cause of deterioration.
- 2) Pressing down the unit lower lever for unit wearing, insert the projection for unit fixing in the fixing hole of the base unit surely, and install with the unit fixing hole as a fulcrum. If the unit is not installed correctly, it will become the cause of malfunction, failure, and drop. If it uses it in the environment with much vibration, fix the unit with the screw. Please perform bolting of the screw in the regulation torque range. If bolting of the screw is loose, it will become the cause of drop, the short circuit, and malfunction. If the screw is tightened too much, it will become the cause of drop by breakage of the screw or the unit, the short circuit, and malfunction.
- 3) Please be sure to do the installing and removing of the unit after shutting down all phase of the external power supply currently used by the system.
- 4) The installing and removing of the unit and the base may be less than 50 times after product use. It may become the cause of malfunction if it exceeds 50 times.
- 5) Please do not touch the electric conduction section or electronic components of the unit directly. It becomes malfunction of the unit, and the cause of failure.

The installation procedure of the base unit is shown in the following.

- a) Fix two mounting screws for the upper side of the base unit to the control panel.



- b) Place the notch on the right side of the base unit to a screw on the right side of the panel.
When the RQ extension base unit is used, place the bell-shaped hole on the right side of the base unit to the screw on the right side of the panel.

<Basic base unit, extension base unit>

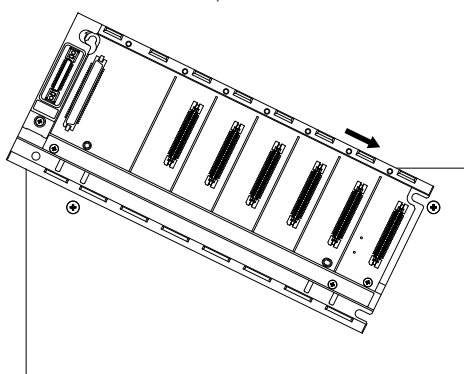

<RQ extension base unit>

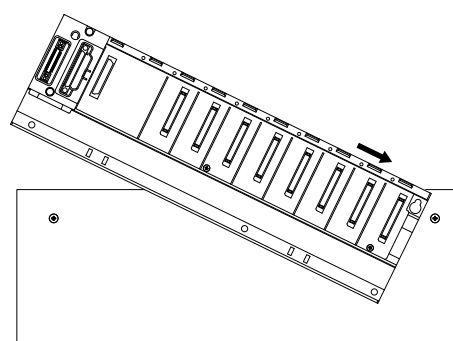

- c) Place the bell-shaped hole on the left side of the base unit to a screw on the left side of the panel.

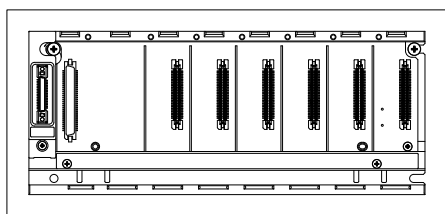

- d) Fix the mounting screws into the holes at the bottom of the base unit, and retighten all the mounting screws.

Notes: In the condition that the right end slot is vacated, install the basic base unit in the plate. When you remove, remove the basic base unit after removing the unit of the right end slot.

(2) Notes on base unit installation

If it installs the robot CPU system in the plate etc., please fully take into consideration the operativity, conservativeness, and environment-proof.

1) Installation position for unit

To improve the airflow and change a module easily, provide clearance between the module top/bottom and structures/parts as shown below.

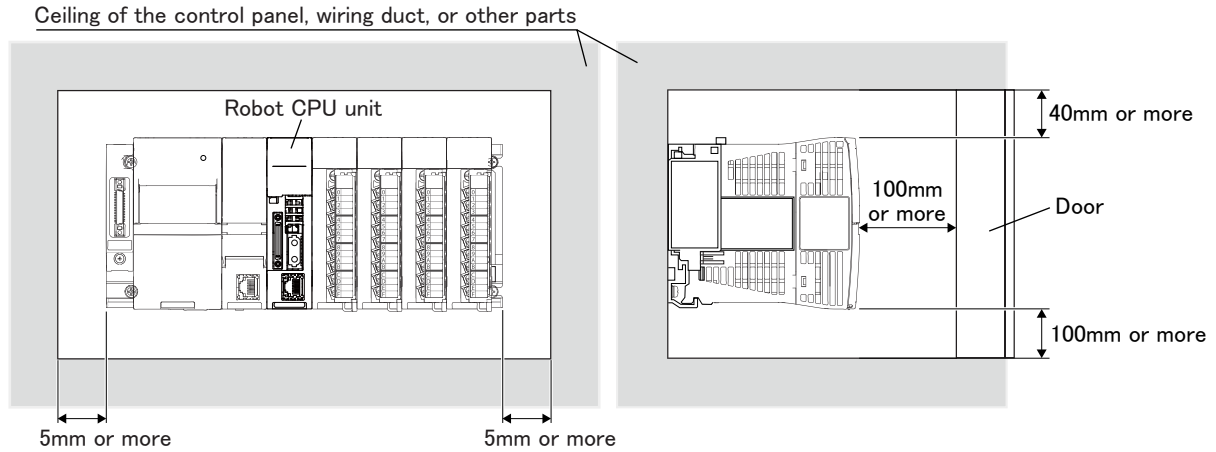
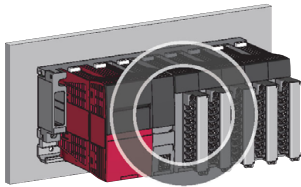

Fig. 2-4 : Installation dimension of the robot CPU unit

2) Unit installation direction

a) Use the robot CPU system in the installation direction of the airy following figure because of heat dissipation.



b) Don't use it in the installation direction of the following figure.

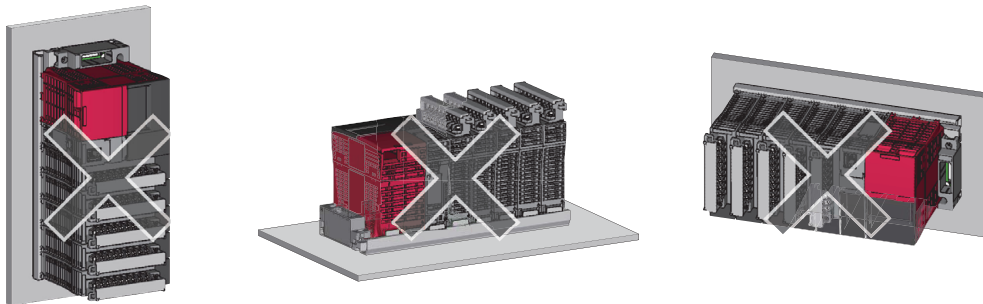

4) Installation surface

Install the base unit in the flat field. If the installation surface has unevenness, impossible force is applied to printed circuit board, and it will become the cause of fault.

5) Mixture with other equipment

Mixture with the sources of vibration, such as large-sized magnetic contact and the no fuse breaker, is avoided, and make it another panel, or detach and install.

6) Distance with other equipment

Because of to avoid the effect of the radiation noise or the heat, please secure the following distance for the robot CPU system and the equipment (the contactor and relay).

- Front of the robot CPU system100mm or more
- Horizontal direction of the robot CPU system50mm or more

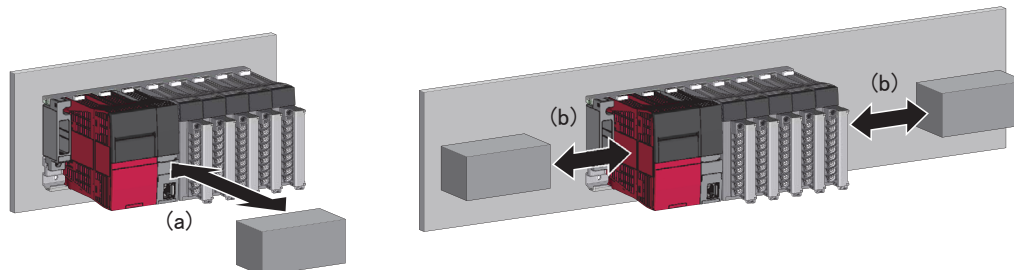

(3) Installation and removal of the unit

The installing-and-removing procedure to base units, such as the power supply unit, the sequencer CPU unit, the robot CPU unit, the input-and-output unit, and the intelligent functional unit, is shown in the following.

■ Installation

- 1) When a cap is attached to the unit connector of the base unit, remove it.
- 2) Place the concave part (a) of an unit onto the guide (b) of the base unit.

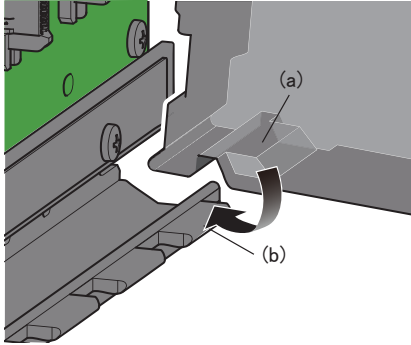

- 3) Push in the unit until the module fixing hook (c) snaps into place.

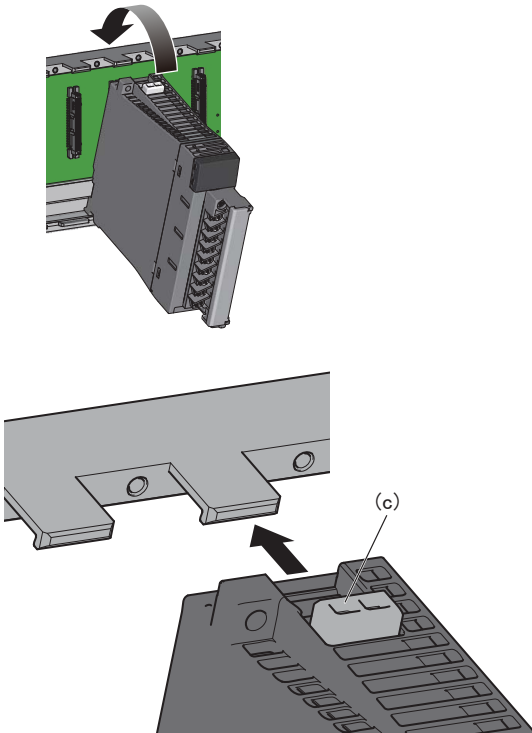

Check that the unit fixing hook (c) hangs the base unit and the unit is mounted on the base unit securely.

- 4) Fix the unit on the base unit with the screws.

[Note]

- Make sure to tighten all the unit fixing screws to prevent the unit from falling.
- The user needs to prepare the unit fixing screws (M3x12).

■ Removal

- 1) Remove unit fixing screws.
- 2) Support the unit with both hands and securely press the unit fixing hook (a) with your finger.

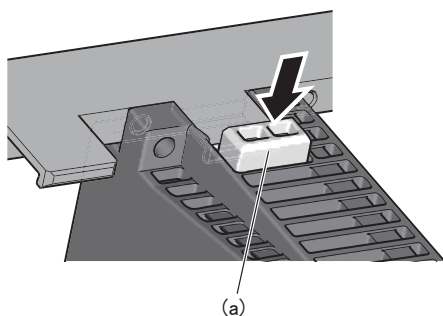

- 3) Pull the unit straight supporting it at its bottom while pressing the unit fixing hook (a).

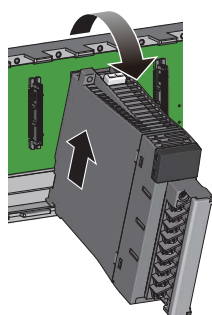

While lifting the unit, remove the concave part (b) from the guide (c) of the base unit.

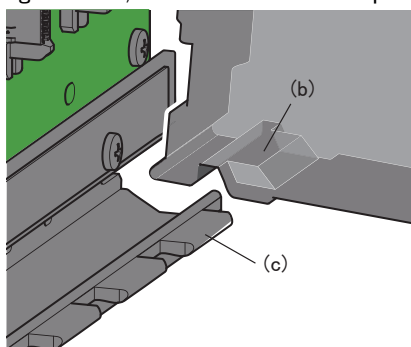

⚠ CAUTION

When unit fixing screws are used, remove the screws first and unit from the base unit. Failure to do so may damage the unit.

⚠ CAUTION

The unit surface temperature may be high immediately after power-off. When the unit is removed, pay attention to the burn injury.

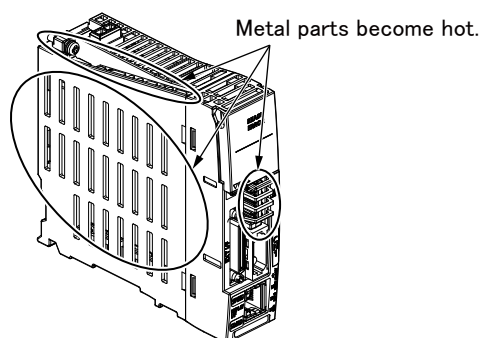

2.3.2 Installation of the robot CPU unit (CR800-Q controller)

(1) Notes on the handling

Explain notes on the handling of the CPU unit, the input/output unit, the intelligent functional unit, the power supply unit, the base unit, etc.

- 1) Please do not drop the unit, the terminal stand connector, and the pin connector, or do not supply a strong shock.
- 2) The printed circuit board of the unit should not remove from the case. It becomes the cause of failure.
- 3) Please carry out bolting of the unit fixing screw and the terminal stand screw in the range shown in [Table 2-2](#).

Table 2-2 : Conclusion torque of the fixing screw

Place of the screw	Bolting torque range
Robot CPU unit fixing screw (M3 × 13)	0.36 ~ 0.48N · m
Unit fixing screw (M3 × 12)	0.36 ~ 0.48N · m
Input/output unit terminal stand screw (M3)	0.42 ~ 0.58N · m
Input/output unit terminal stand attachment screw (M3.5)	0.68 ~ 0.92N · m
Terminal screw of the power supply unit (M3.5)	0.68 ~ 0.92N · m

- 4) The basic base unit should equip with the power supply unit at any cost. If the load of the input/output unit and intelligent functional unit with which the base unit is equipped is low, it may operate, even if there is no power supply unit. However, since voltage becomes unstable, operation cannot be guaranteed.
- 5) Since it may malfunction by vibration if it installs the basic base unit in the plate, please be sure to fix with the screw for fixing.

 CAUTION

- 1) Please use the robot CPU system in the environment of general specification given in this manual. If other, it becomes the electric shock, the fire, malfunction, the damage to the product, or the cause of deterioration.
- 2) Pressing down the unit lower lever for unit wearing, insert the projection for unit fixing in the fixing hole of the base unit surely, and install with the unit fixing hole as a fulcrum. If the unit is not installed correctly, it will become the cause of malfunction, failure, and drop. If it uses it in the environment with much vibration, fix the unit with the screw. Please perform bolting of the screw in the regulation torque range. If bolting of the screw is loose, it will become the cause of drop, the short circuit, and malfunction. If the screw is tightened too much, it will become the cause of drop by breakage of the screw or the unit, the short circuit, and malfunction.
- 3) Please be sure to do the installing and removing of the unit after shutting down all phase of the external power supply currently used by the system.
- 4) The installing and removing of the unit and the base may be less than 50 times after product use. It may become the cause of malfunction if it exceeds 50 times.
- 5) Please do not touch the electric conduction section or electronic components of the unit directly. It becomes malfunction of the unit, and the cause of failure.

 CAUTION

When a CPU error occurred in the PLC, the robot CPU can operate without error. When the robot operation is stopped when a CPU error occurred, periodically communicate between the PLC CPU and robot CPU, and check the operating status in robot program.

The installation procedure of the basic base unit is shown in the following.

- a) Install the two screws for fixing for basic base unit surface to the plate.

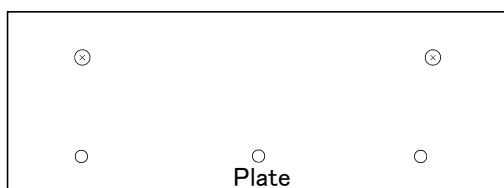

- b) Hook the hollow on the right side of the basic base unit on the right side screw.

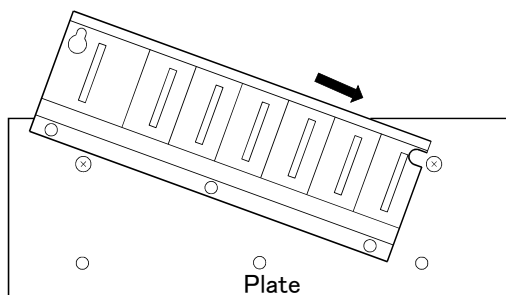

- c) Hook the long hole on the left side of the basic base unit on the left side screw.

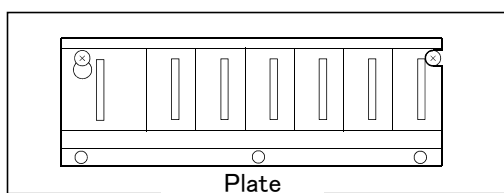

- d) Install the fixing screw in the fixing screw hole of the basic base unit bottom, and retighten all the fixing screws securely.

Notes: In the condition that the right end slot is vacated, install the basic base unit in the plate. When you remove, remove the basic base unit after removing the unit of the right end slot.

(2) Notes on base unit installation

If it installs the robot CPU system in the plate etc., please fully take into consideration the operativity, conservativeness, and environment-proof.

1) Installation dimension

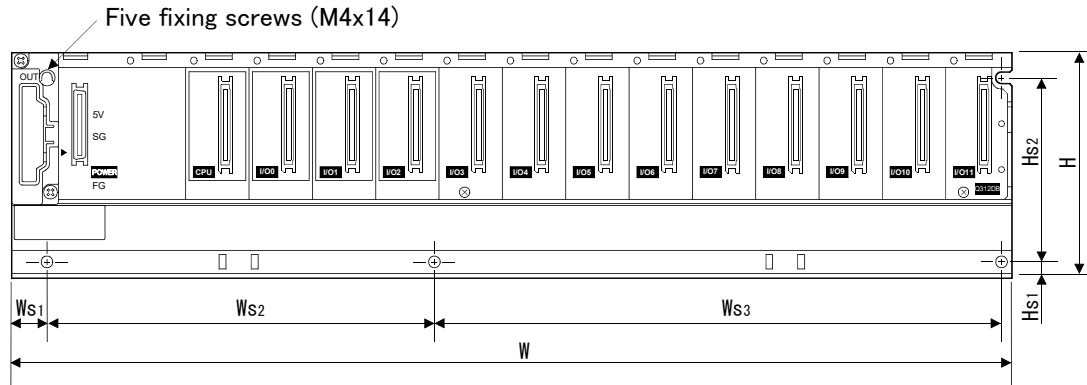

Table 2-3 : Installation dimension

Dimension place	Q38DB	Q312DB
W	328	439
Ws1	15.5	
Ws2	170±0.3	
Ws3	138±0.3	249±0.3
H	98	
Hs1	7	
Hs2	80±0.3	

2) Unit installation position

Secure the following distance for the unit up-and-down section, and the structure and the parts, and breathability and the convertibility of the unit are upgraded.

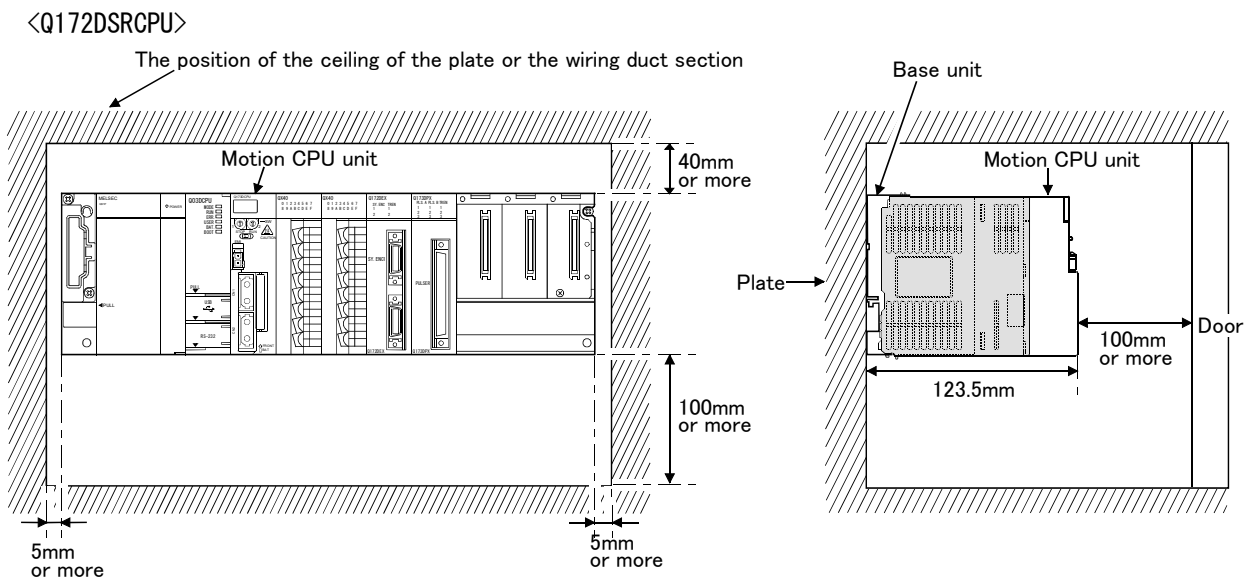
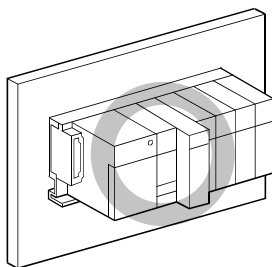

Fig. 2-5 : Installing dimensions of the robot CPU unit

3) Unit installation direction

- a) Use the robot CPU system in the installation direction of the air following figure because of heat dissipation.



- b) Don't use it in the installation direction of the following figure.

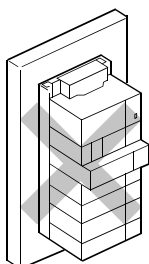

Vertical installation

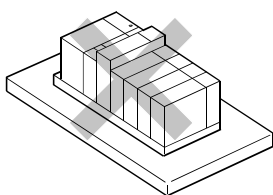

Horizontal installation

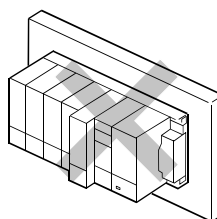

Upside down installation

4) Installation surface

Install the base unit in the flat field. If the installation surface has unevenness, impossible force is applied to printed circuit board, and it will become the cause of fault.

5) Mixture with other equipment

Mixture with the sources of vibration, such as large-sized magnetic contact and the no fuse breaker, is avoided, and make it another panel, or detach and install.

6) Distance with other equipment

Because of to avoid the effect of the radiation noise or the heat, please secure the following distance for the robot CPU system and the equipment (the contactor and relay).

- Front of the robot CPU system100mm or more
- Horizontal direction of the robot CPU system50mm or more

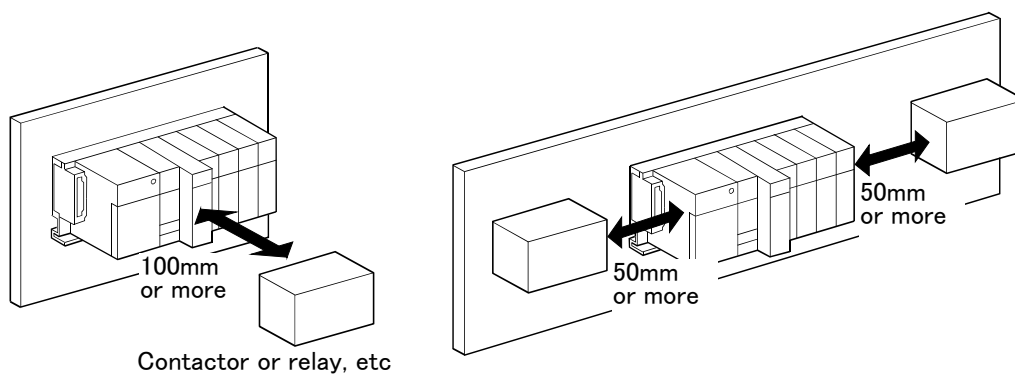

(3) Installation and removal of the unit

The installing-and-removing procedure to base units, such as the power supply unit, the sequencer CPU unit, the robot CPU unit, the input-and-output unit, and the intelligent functional unit, is shown in the following.

1) Installing and removing of the unit to the base unit "Q3 □ DB"

a) Installation to "Q3 □ DB"

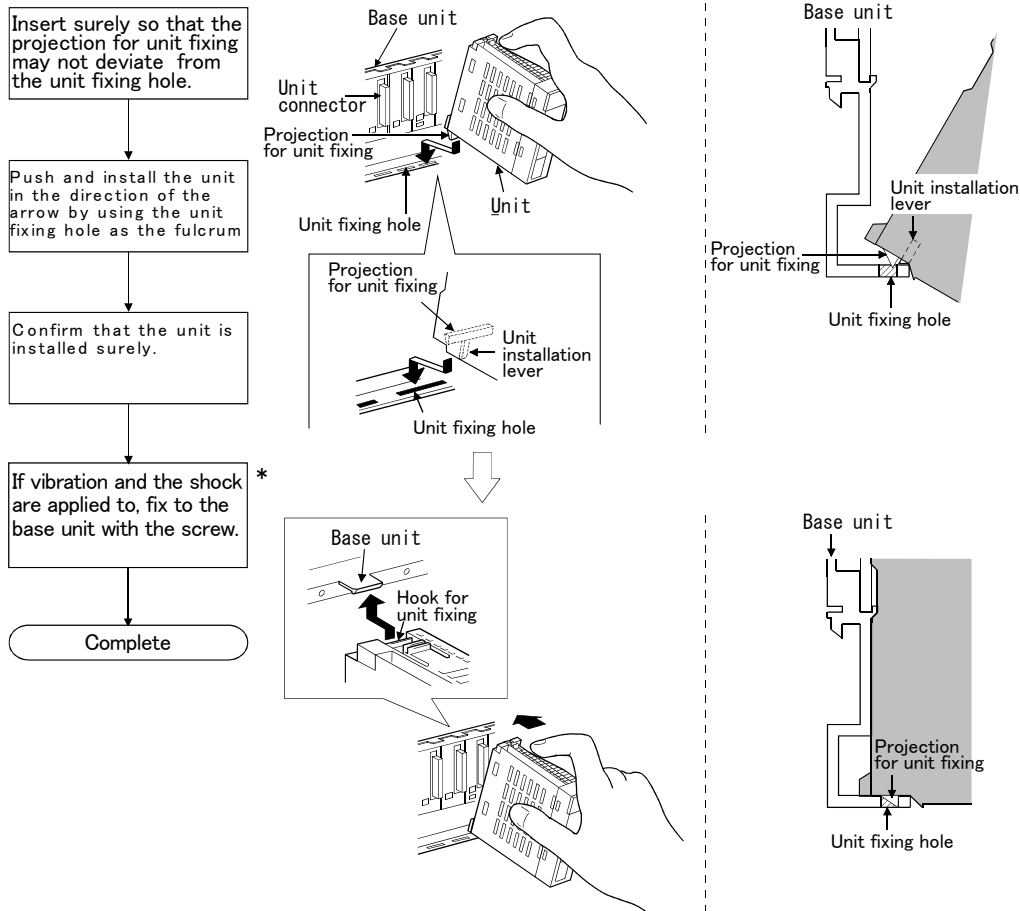

*: Please be sure to fix the robot CPU unit to the base unit with the screw.

<Point>

- The unit should insert the projection for unit fixing in the unit fixing hole always. In that case, insert surely so that the projection for unit fixing may not deviate from the unit fixing hole. If it installs forcibly, without inserting, the unit connector and the unit will be damaged.
- If it uses it at the place which is applied to of vibration and the shock, fix the unit to the base unit with the screw. Unit fixing screw: M3x12 (prepare by the customer) Always fix the robot CPU unit to the base unit with the screw with the attached unit fixing screw (M3x13).
- The installing and removing of the unit and the base may be less than 50 times after product use. It may become the cause of malfunction if it exceeds 50 times.

CAUTION

Pressing down the unit lower lever for unit wearing, insert the projection for unit fixing in the fixing hole of the base unit surely, and install with the unit fixing hole as a fulcrum. If the unit is not installed correctly, it will become the cause of malfunction, failure, and drop. If it uses it in the environment with much vibration, fix the unit with the screw. Please perform bolting of the screw in the regulation torque range. If bolting of the screw is loose, it will become the cause of drop, the short circuit, and malfunction. If the screw is tightened too much, it will become the cause of drop by breakage of the screw or the unit, the short circuit, and malfunction.

b) Removing from "Q3 □ DB"

Remove the screw, if the unit fixing screw is being used.

Hold the unit with both hands and push the upside hook for fixing, until it stops.

Push the hook for unit fixing, use lower part as the fulcrum and pull it to the front.

Holding up the unit, and remove the projection section for fixing from the hole

Complete

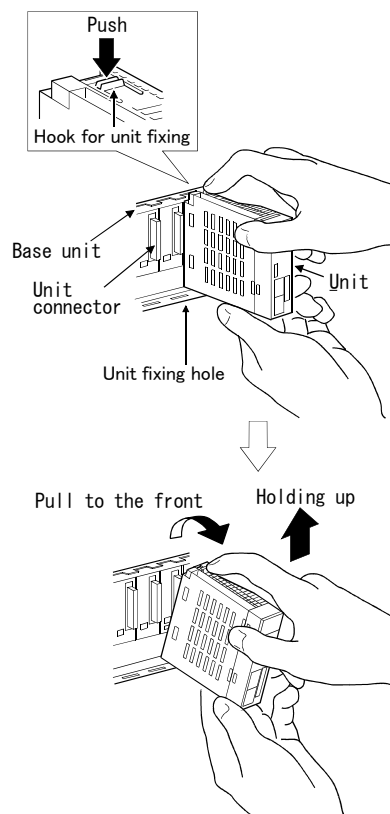

<Point>

- Remove the screw, if the unit fixing screw is being used. Next, remove the projection for unit fixing from the unit fixing hole. If it tries to remove the unit by force, the projection for unit fixing will be damaged.

CAUTION

Since the heat dissipation fin of the robot CPU unit may become the high temperature for a power supply on, and after power supply off, please do not touch. It becomes the cause of the burn. When you remove the unit, be careful of the handling.

2.3.3 Connecting the power cable and grounding cable

The following shows how to connect the power cables and grounding cables.

CAUTION

Please install the earth leakage breaker in the primary side power supply of the controller because of leakage protection.

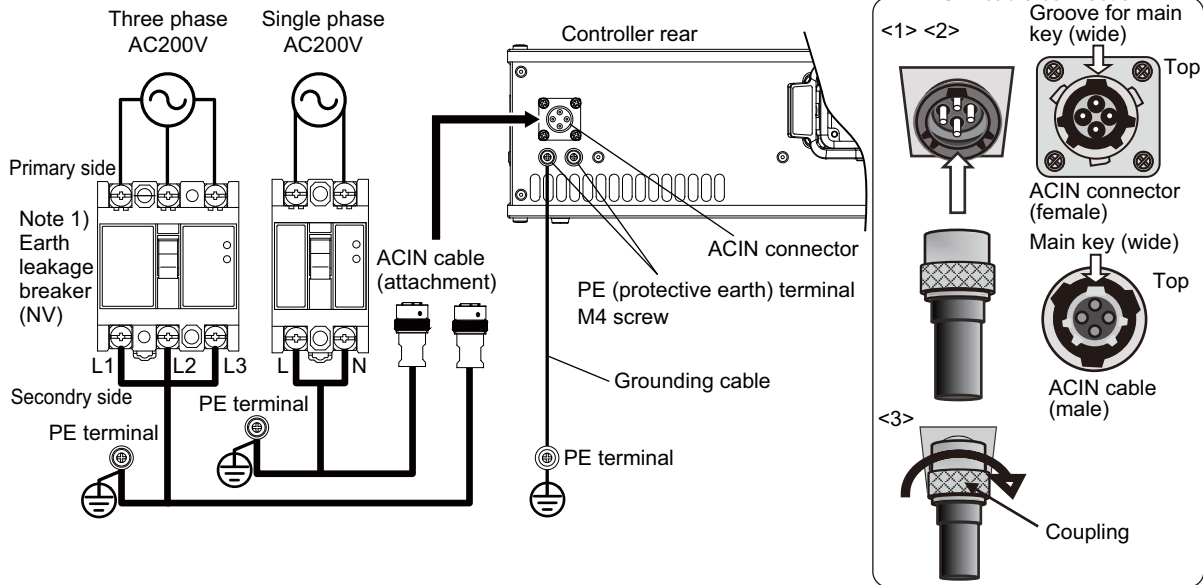

Note 1) Always use the terminal cover for the earth leakage breaker.

1) Prepare the following items.

Part name	Specifications	Remarks
Earth leakage breaker	The following is recommended product. Single phase: NV30FAU-2P-10A-AC100-240V-30mA (Terminal cover: TCS-05FA2) Three phase: NV30FAU-3P-10A-AC100-240V-30mA (Terminal cover: TCS-05FA3)	Prepared by customer.
Cable for primary power supply	AWG14 (2mm ²) or above	Prepared by customer. Tightening torque for terminal fixing screw is 2 ~ 3Nm.
Grounding cable	AWG14 (2mm ²) or above	Prepared by customer. Tightening torque for terminal fixing screw is 2 ~ 3Nm.
ACIN cable	Terminal: M5, cable length: 3m	Supplied with the product.

- 2) Confirm that the primary power matches the specifications.
- 3) Confirm that the primary power is OFF and that the earth leakage breaker power switch is OFF.
- 4) Connect the ACIN cable to the breaker.
Connect the power terminals of the ACIN cable to the secondary side terminals of the earth leakage breaker. Also, ground the FG terminal of the cable.
- 5) Connect the ACIN cable to the ACIN connector on the rear of the controller.
<1> Face the main key on the ACIN cable plug upwards. (Refer to the "ACIN cable connection" illustration.)
<2> Align the main key of the ACIN cable plug with the grooves on the ACIN connector. Push the plug into the connector as far as it will go.
The plug may be damaged if it is not correctly aligned with the connector.
<3> Tighten the coupling on the ACIN cable, turning it to the right until it locks.
- 6) Connect one end of the grounding cable to the PE (protective earth) terminal on the controller and ground the other end (2-point grounding) in order to comply with the requirements of EN 61800-5-1 for the touch current of 3.5 mA AC or more.
- 7) Connect the primary power cable to the primary side terminal of the earth leakage breaker.

Connecting the power cable and grounding cable is completed.

2.3.4 Connection between the robot CPU unit and the drive unit

The connection method of the robot CPU unit and the controller is shown below. Connect with reference to Fig. 2-6.

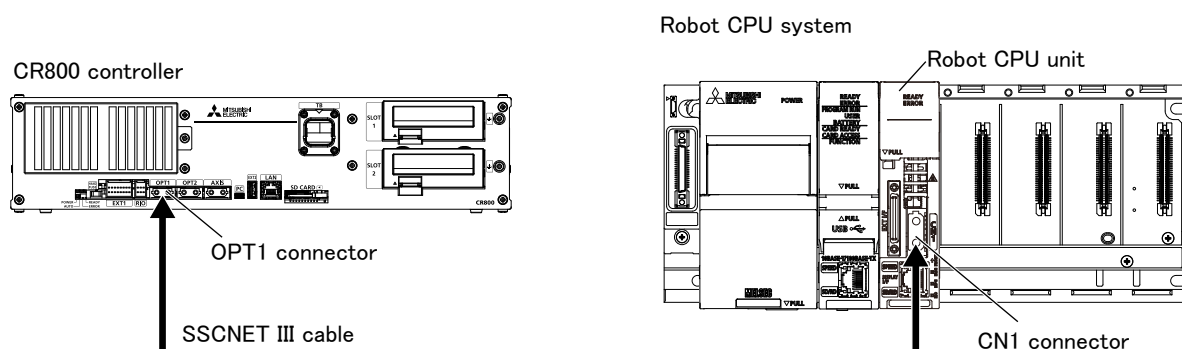

Fig. 2-6 : Connection between the robot CPU system and the controller

CAUTION

- 1) If the cap is not installed in the SSCNET III connector after removing the SSCNET III cable, there is a possibility that the characteristic may deteriorate and malfunction by adhesion of garbage and the dust
- 2) Don't remove the SSCNET III cable, when the power supply of the robot CPU system or servo amplifier is turned on. Don't face squarely the light emitted from motion CPU or the tip of the SSCNET III connector of servo amplifier, and the SSCNET III cable. If light hits to the eyes, there is a possibility of feeling the sense of incongruity for the eyes. (The light source of SSCNET III is equivalent to the class 1 specified to JISC6802 and IEC60825-1.)
- 3) Install the SSCNET III cable in the larger radius than minimum flexed radius shown in the following sure.

Type	Minimum flexed radius [mm]
MR-J3BUS10M-A	Reinforcement skin section: 50 Code section: 25

2.3.5 Emergency stop input and output etc.

Do wiring of the external emergency stop, the special stop input, the door switch, and the mode selector switch from the "special input/output" terminal connector.

Connection of the external emergency stop is explained in "2.3.6 Connecting the external emergency stop and mode selector switch". And about wiring of the others, refer to separate "Standard Specifications Manual".

Table 2-4 : Special input/output terminal

Item	Name	Function
Input	Emergency stop	Applies the emergency stop. Dual emergency line.
Input	Special stop input	Applies the stop. (Refer to "Special stop input (SKIP)" in separate "Standard Specifications Manual".)
Input	Door switch	Servo-off. Dual line, normal close. (Refer to "Door switch function" in separate "Standard Specifications Manual".)
Input	Mode selector switch	Changes the mode (MANUAL/AUTOMATIC) of the controller. Dual line. (Refer to "Enabling device function" in separate "Standard Specifications Manual".)
Output	Robot error output	Contact is opening during error occurrence.
Output	Emergency stop output	The point of contact opens under occurrence of emergency stop of external input signal, emergency stop of OP, emergency stop of T/B.
Output	Mode output	MANUAL mode: contactor is opening, AUTOMATIC mode: contactor is closing.
Output	Additional axis synchronization output	When an additional axis is used, the servo ON/OFF status of the additional axis can be synchronized with the robot arm. (Refer to Page 36, "2.3.8 Additional axis synchronization output".)

*At the time of the power supply OFF, the output point of contact is always open.

[Note] The contact capacity of each input/output terminal is DC24V/100mA. Don't connect the equipment except for this range. Noise or other effects that overload contact capacities will lead to failure. An example of noise prevention is shown in Fig. 2-7.

In the customer's system, do not ground the + side of 24V power supply prepared by customer for connect to the controller. (related with emergency stop and parallel input/output) If it connects with the controller under the condition that the + side is grounded, it will lead to failure of controller.

An example of connecting devices such as PLCs

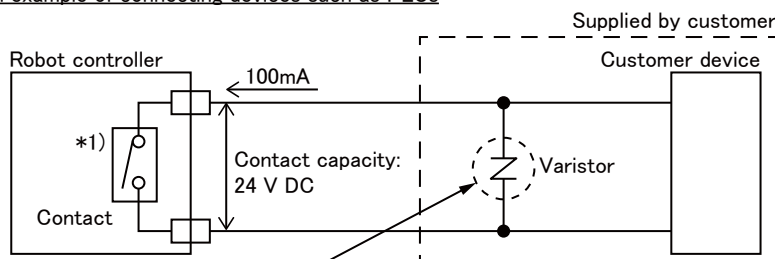

Use noise prevention methods that are specific to the devices being used and the environment they are being used in.

An example of connecting devices such as relays

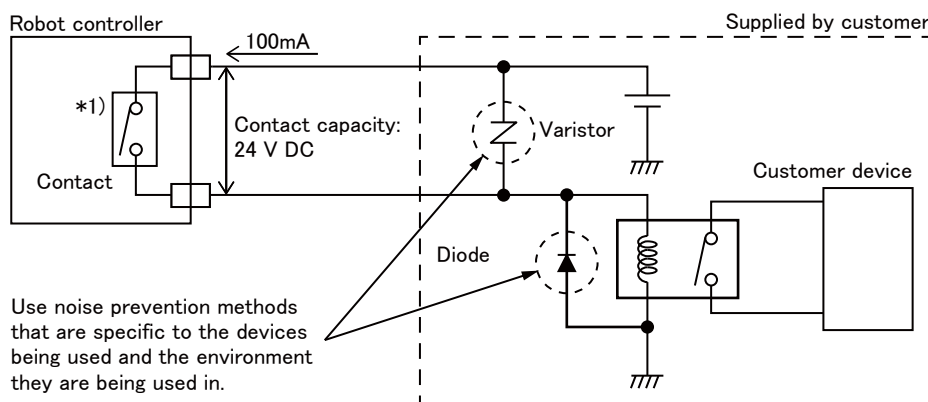

Use noise prevention methods that are specific to the devices being used and the environment they are being used in.

*1) The actual internal robot controller circuit differs from the internal robot controller circuit in the figure.

Recommended varistor

Model	Manufacturer	Varistor voltage	Max. permissible circuit voltage
ERZV10D390	Panasonic	39V	31V
72210S0250K101	TDK	39V	31V

Fig.2-7 : Protection circuit example

[Note] If a stop signal or servo OFF signal is input simultaneously with a door switch open/emergency stop input, the error, H056n “Servo sys. error (A/D)” may occur.

When a door switch open/emergency stop is input, the robot turns off the servo after it stops. It is unnecessary to input a stop signal or servo OFF signal. To input a stop signal or servo OFF signal with a door switch open/emergency stop input, wait for 100ms or more after a door switch open/emergency stop input.

2.3.6 Connecting the external emergency stop and mode selector switch

The following shows how to connect the external emergency stop.

For external emergency stop, connect to the connector of the controller (see Fig. 2-8).

The input terminals for the external emergency stop, door switch, and mode selector switch are arranged as shown in Fig. 2-9. Customers should be sure to prepare the external emergency stop, door switch, and mode selector switch, etc. and use the robot while these are connected. Connection procedures are shown below.

In addition, refer to “2.3.7 Examples of safety measures” for the information on the emergency stop connection and cautions.

[Caution] The emergency stop circuit is duplicated inside the controller. The emergency stop switch uses a double contact-type switch, so please be sure to fix both of the contacts to the connector pins as shown below in order to ensure the wiring is duplicated. An error will continue to occur in the event that only one of the pins is connected.

- 1) Please prepare the emergency stop switch, door switch, and mode selector switch.
- 2) Connect the contacts of each switch to the contacts as shown below:
 - a) External emergency switch
CNUSR11 connector “between 7 and 23” and “between 14 and 30”.
 - b) Door switch
CNUSR11 connector “between 6 and 22” and “between 13 and 29”.
 - c) Mode selector switch
CNUSR11 connector “between 5 and 21” and “between 12 and 28”.

[Caution] Be sure to use a shield cable for the emergency stop wiring cable. And when operating in an environment that is easily affected by noise, be sure to install the ferrite core (recommended model name: E04SR301334, manufacturer: Seiwa Electric Mfg. Co., Ltd.). Be sure to place the ferrite core in 300mm or less from the connecting terminal section.

CAUTION

Make sure there are no mistakes in the wiring. Connecting differently to the way specified in the manual can result in failures, such as the emergency stop not being released. In order to prevent from occurring, please be sure to check that all functions (such as the teaching box emergency stop, customer emergency stop, and door switch) are working properly after the wiring setup is completed.

CAUTION

You should always connect doubly connection of the emergency stop, the door switch, and the mode selector switch. In connection of only one side, if the relay of customer use should break down, it may not function correctly.

The robot output contacts (error output, emergency stop output, mode output, additional axis synchronization output) are duplicated output contacts that are wired in series. As with emergency stop switches and door switches, ensure that all connections to customer devices are duplicated to achieve redundancy.

CAUTION

When using several emergency stop switches, perform wiring carefully to make sure that each emergency stop switch functions independently. Check and make sure that the emergency stop does not function under an AND condition (when multiple emergency stop switches are ON at the same time).

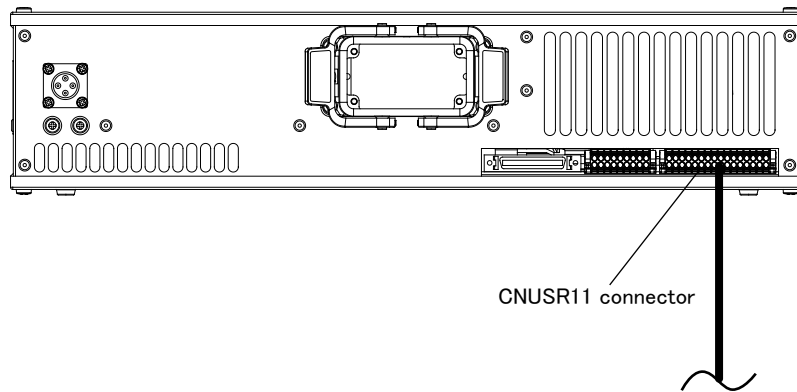

Fig. 2-8 : Emergency stop cable and mode selector switch connection

Refer to the following for details on the example of external emergency stop connection, arrangement of connectors for exclusive input/output signals, and pin assignment.

Item	Reference
Example of external emergency stop connection	Fig. 2-9
Arrangement of connectors for exclusive input/output signals	Fig. 2-10
Pin assignment	CNUSR11 connector: Table 2-5 CNUSR12 connector: Table 2-6

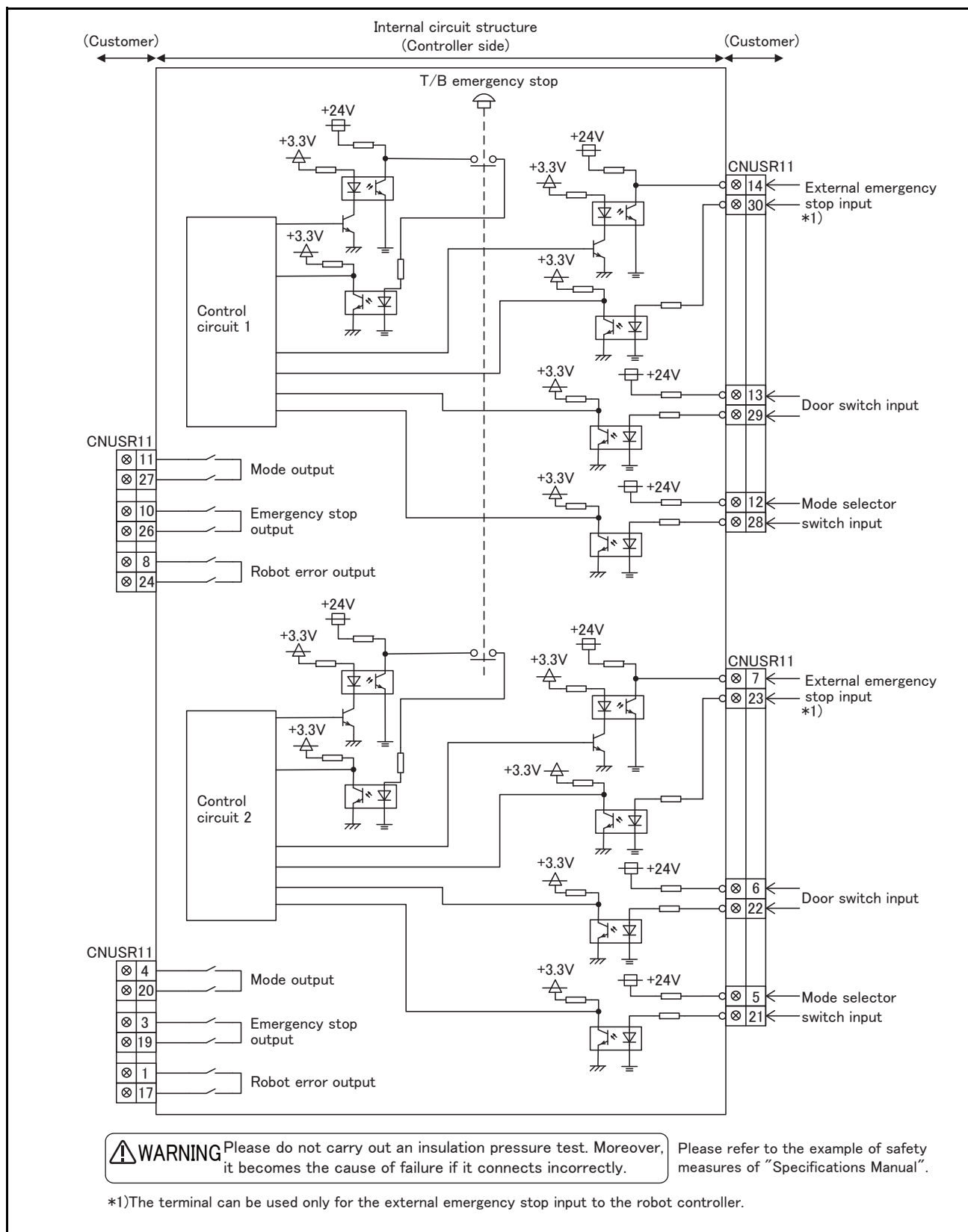

Fig. 2-9 : External emergency stop connection

⚠ CAUTION

Place the emergency stop switch in an easily operable position, and be sure to wire it to the emergency stop correctly by refer to [Page 31, "2.3.7 Examples of safety measures"](#). This is a necessary measure in order to ensure safe operation so that the robot can be stopped immediately by pressing the emergency stop switch in the event that the robot malfunctions.

Arrangement of connectors for exclusive input/output signals are shown in Fig. 2-10. The pin assignments of the connectors for exclusive input/output signals are shown in Table 2-5 and Table 2-6.

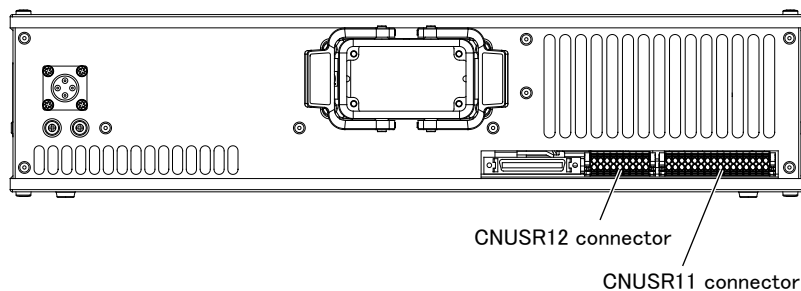

Fig. 2-10 : Arrangement of connectors for exclusive input/output signals

Table 2-5 : Pin assignment (CNUSR11)

Pin No.	Name	Function	Remarks	Pin No.	Name	Function	Remarks
1	ROBOTERR21	Robot error output	This pin and pin 17 is a pair.	17	ROBOTERR22	Robot error output	This pin and pin 1 is a pair.
2	AXMC21	Additional axis synchronization output	To synchronize an additional axis to a robot's servo ON/OFF. This pin and pin 18 is a pair.	18	AXMC22	Additional axis synchronization output	To synchronize an additional axis to a robot's servo ON/OFF. This pin and pin 2 is a pair.
3	EMGOUT21	Emergency stop output	Confirming the presence/absence of an emergency stop. This pin and pin 19 is a pair.	19	EMGOUT22	Emergency stop output	Confirming the presence/absence of an emergency stop. This pin and pin 3 is a pair.
4	MODEOUT21	Mode output	Confirming the controller operation mode. This pin and pin 20 is a pair.	20	MODEOUT22	Mode output	Confirming the controller operation mode. This pin and pin 4 is a pair.
5	OPKEY2COM(2 4V)	Mode selector switch input	Switching an operation mode of a controller. This pin and pin 21 is a pair.	21	OPKEY2	Mode selector switch input	Switching an operation mode of a controller. This pin and pin 5 is a pair.
6	24V2 for DOOR	Connection of door switch	Detecting the opening and closing of a door. This pin and pin 22 is a pair.	22	DOOR2	Connection of door switch	Detecting the opening and closing of a door. This pin and pin 6 is a pair.
7	EXTEMG21	Construction of external emergency stop input circuit	Constructing an external emergency stop function.	23	EXTEMG22	Construction of external emergency stop input circuit	Constructing an external emergency stop function.
8	ROBOTERR11	Robot error output	This pin and pin 24 is a pair.	24	ROBOTERR12	Robot error output	This pin and pin 8 is a pair.
9	AXMC11	Additional axis synchronization output	To synchronize an additional axis to a robot's servo ON/OFF. This pin and pin 25 is a pair.	25	AXMC12	Additional axis synchronization output	To synchronize an additional axis to a robot's servo ON/OFF. This pin and pin 9 is a pair.
10	EMGOUT11	Emergency stop output	Confirming the presence/absence of an emergency stop. This pin and pin 26 is a pair.	26	EMGOUT12	Emergency stop output	Confirming the presence/absence of an emergency stop. This pin and pin 10 is a pair.

Pin No.	Name	Function	Remarks	Pin No.	Name	Function	Remarks
11	MODEOUT11	Mode output	Confirming the controller operation mode. This pin and pin 27 is a pair.	27	MODEOUT12	Mode output	Confirming the controller operation mode. This pin and pin 11 is a pair.
12	OPKEY1COM(24V)	Mode selector switch input	Switching an operation mode of a controller. This pin and pin 28 is a pair.	28	OPKEY1	Mode selector switch input	Switching an operation mode of a controller. This pin and pin 12 is a pair.
13	24V1 for DOOR	Connection of door switch	Detecting the opening and closing of a door. This pin and pin 29 is a pair.	29	DOOR1	Connection of door switch	Detecting the opening and closing of a door. This pin and pin 13 is a pair.
14	EXTEMG11	Construction of external emergency stop input circuit	Constructing an external emergency stop function.	30	EXTEMG12	Construction of external emergency stop input circuit	Constructing an external emergency stop function.
15		Reserved		31		Reserved	
16		Reserved		32		Reserved	

Table 2-6 : Pin assignment (CNUSR12)

Pin No.	Name	Function	Remarks	Pin No.	Name	Function	Remarks
1	SKIP41	SKIP41 common (COM)	This pin and pin 10 is a pair.	10	SKIP42	SKIP4 input	This pin and pin 1 is a pair.
2	SKIP31	SKIP31 common (COM)	This pin and pin 11 is a pair.	11	SKIP32	SKIP3 input	This pin and pin 2 is a pair.
3	SKIP21	SKIP21 common (COM)	This pin and pin 12 is a pair.	12	SKIP22	SKIP2 input	This pin and pin 3 is a pair.
4	SKIP11	Dedicated stop input common (COM)	This pin and pin 13 is a pair.	13	SKIP12	Dedicated stop input common	This pin and pin 4 is a pair.
5	LBH2	B-phase signal + (plus) side of differential encoder CH2	Encoder input of a trucking function CH2	14	LBL2	B-phase signal - (minus) side of differential encoder CH2	Encoder input of a trucking function CH2
6	LAH2	A-phase signal + (plus) side of differential encoder CH2		15	LAL2	A-phase signal - (minus) side of differential encoder CH2	
7	ENC5V	5V for encoder signal	5V input	16	RG	GND for encoder signal	GND connection for pin 7 power supply
8	LBH1	B-phase signal + (plus) side of differential encoder CH1	Encoder input of a trucking function CH1	17	LBL1	B-phase signal - (minus) side of differential encoder CH1	Encoder input of a trucking function CH1
9	LAH1	A-phase signal + (plus) side of differential encoder CH1		18	LAL1	A-phase signal - (minus) side of differential encoder CH1	

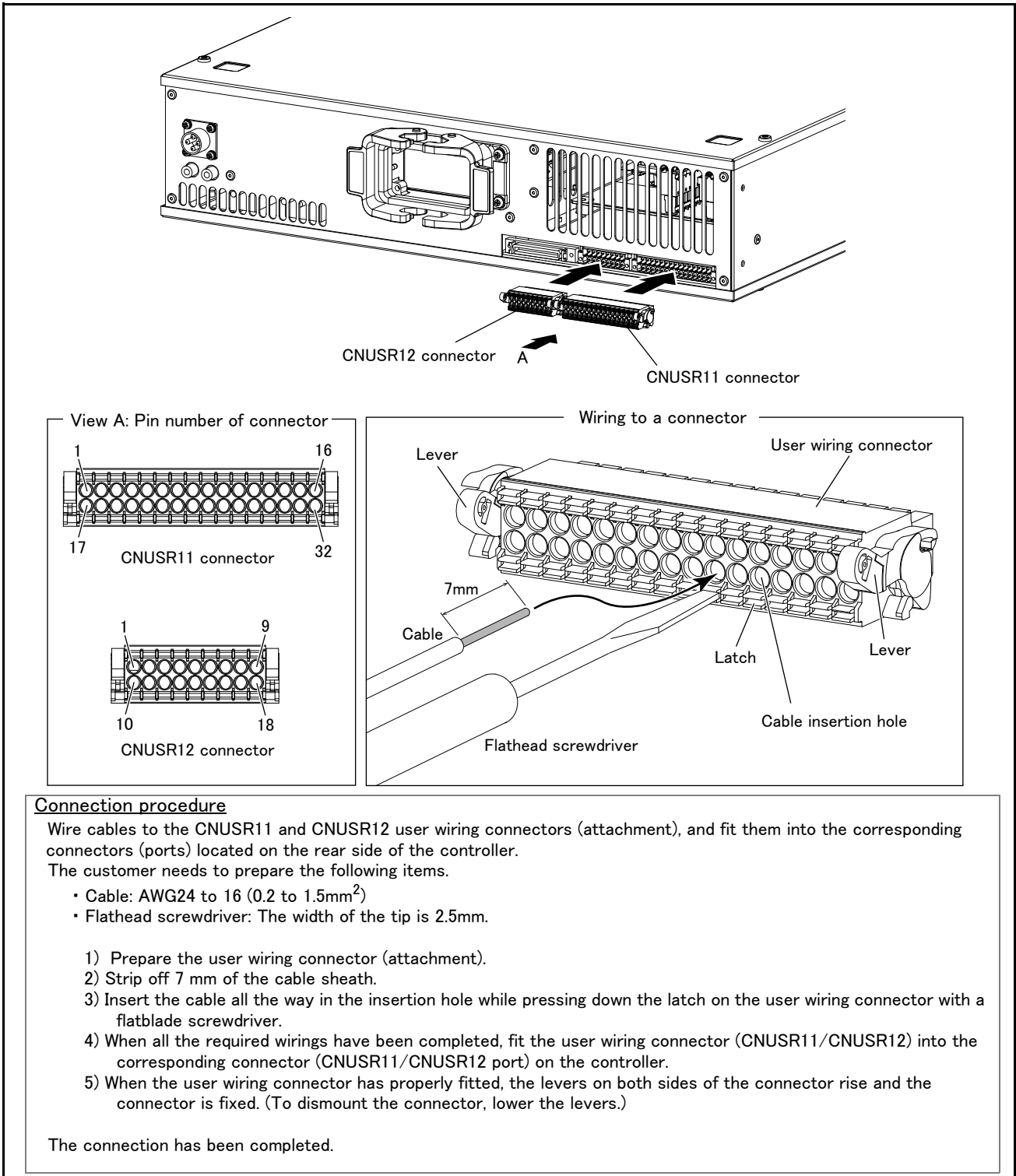

Fig. 2-11 : Wiring method to the user wiring connector

CAUTION

Fully check the number of the cable insertion hole (connector pin number) for incorrect connection. Incorrect wiring may damage the robot or cause a malfunction.

CAUTION

When wiring to the CNUSR11/CNUSR12 connector, pay attention to fraying wires of the core wires. The fraying wires can come into contact with the adjacent terminal, causing a short circuit.

Do not apply solder on core wires. Doing so may cause a contact failure.

2.3.7 Examples of safety measures

The controller's dedicated I/O terminal connector has a duplicate emergency stop circuit.

The safety measure examples are shown in Fig. 2-12 to Fig. 2-15. Create a circuit as shown below for safety measures. In addition, the figure shows the normal state which is not in the emergency stop state.

[Note] · In the emergency-stop related wiring by the customer, if the coil (is not the contact points) of the relay prepared by the customer is connected to the controller, please be sure to implement the measure against the noise by the customer in the coil section. And, please also take the lifetime of noise suppression parts into consideration.

- Electric specification of the emergency-stop-related output terminal: 24V DC or less, related current 100mA or less.
- In the customer's system, do not ground the + side of 24V power supply prepared by customer for connect to the controller. (related with emergency stop and parallel input/output) If it connects with the controller under the condition that the + side is grounded, it will lead to failure of controller.

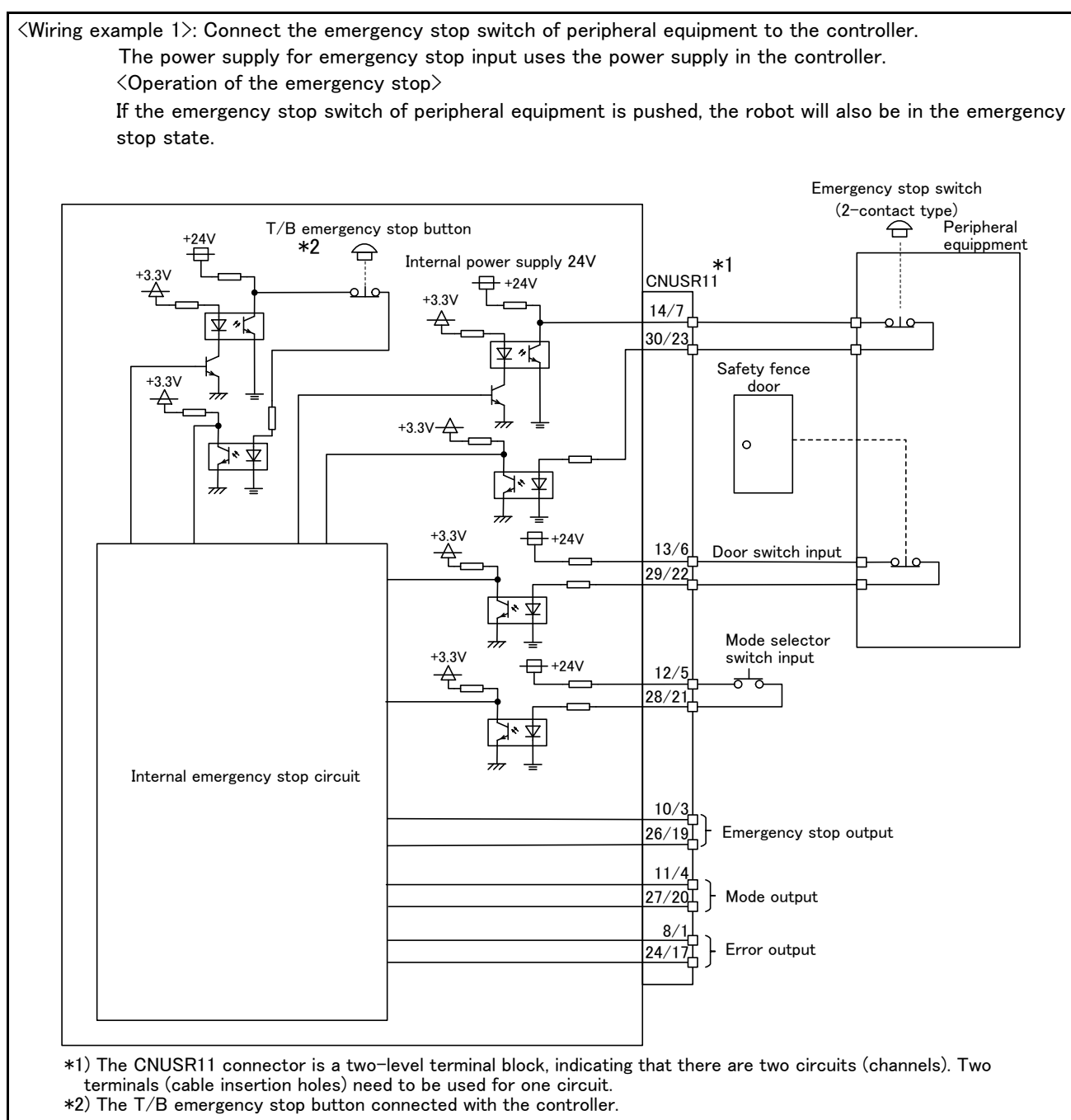

Fig.2-12 : Example of safety measures (wiring example 1)

<Wiring example 2>: Connect the emergency stop switch, and door switch of peripheral equipment to the controller.

The power supply for emergency stop input uses the power supply in the controller. Monitor the emergency stop state by the peripheral equipment side.

<Operation of the emergency stop>

If the emergency stop switch of peripheral equipment is pushed, the robot will also be in the emergency stop state.

When the controller power is OFF, the peripheral devices are in the emergency stop state.

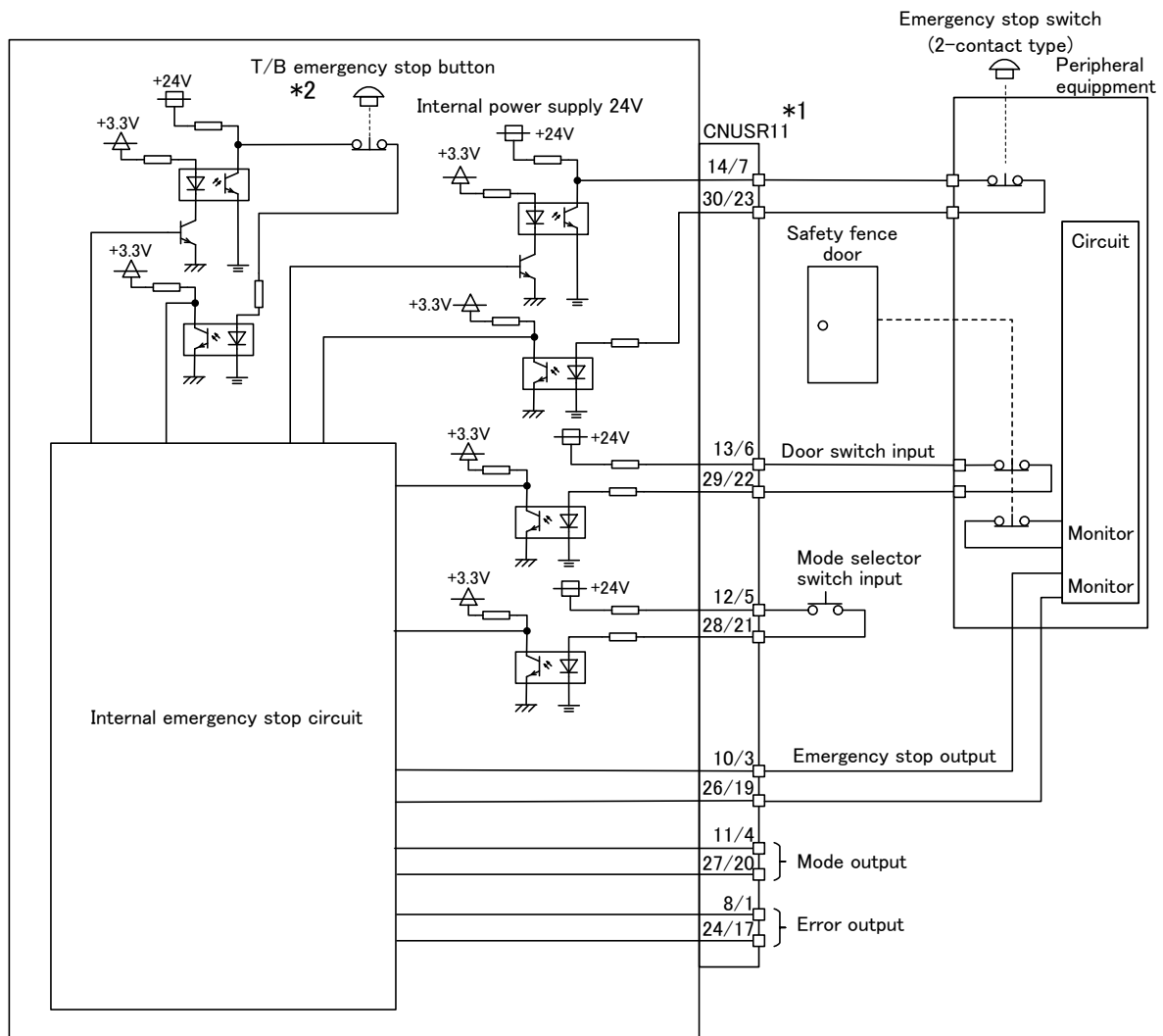

- *1) The CNUSR11 connector is a two-level terminal block, indicating that there are two circuits (channels). Two terminals (cable insertion holes) need to be used for one circuit.
- *2) The T/B emergency stop button connected with the controller.

Fig.2-13 : Example of safety measures (wiring example 2)

<Wiring example 3>: Connect the emergency stop switch of peripheral equipment, and the door switch to two controllers, and it interlocks. The power supply for emergency stop input uses the power supply of peripheral equipment.

Monitor the emergency stop state by the peripheral equipment side.

<Operation of the emergency stop>

If the emergency stop switch of peripheral equipment is pushed, the robot will also be in the emergency stop state. When the controller power is OFF, the peripheral devices are in the emergency stop state.

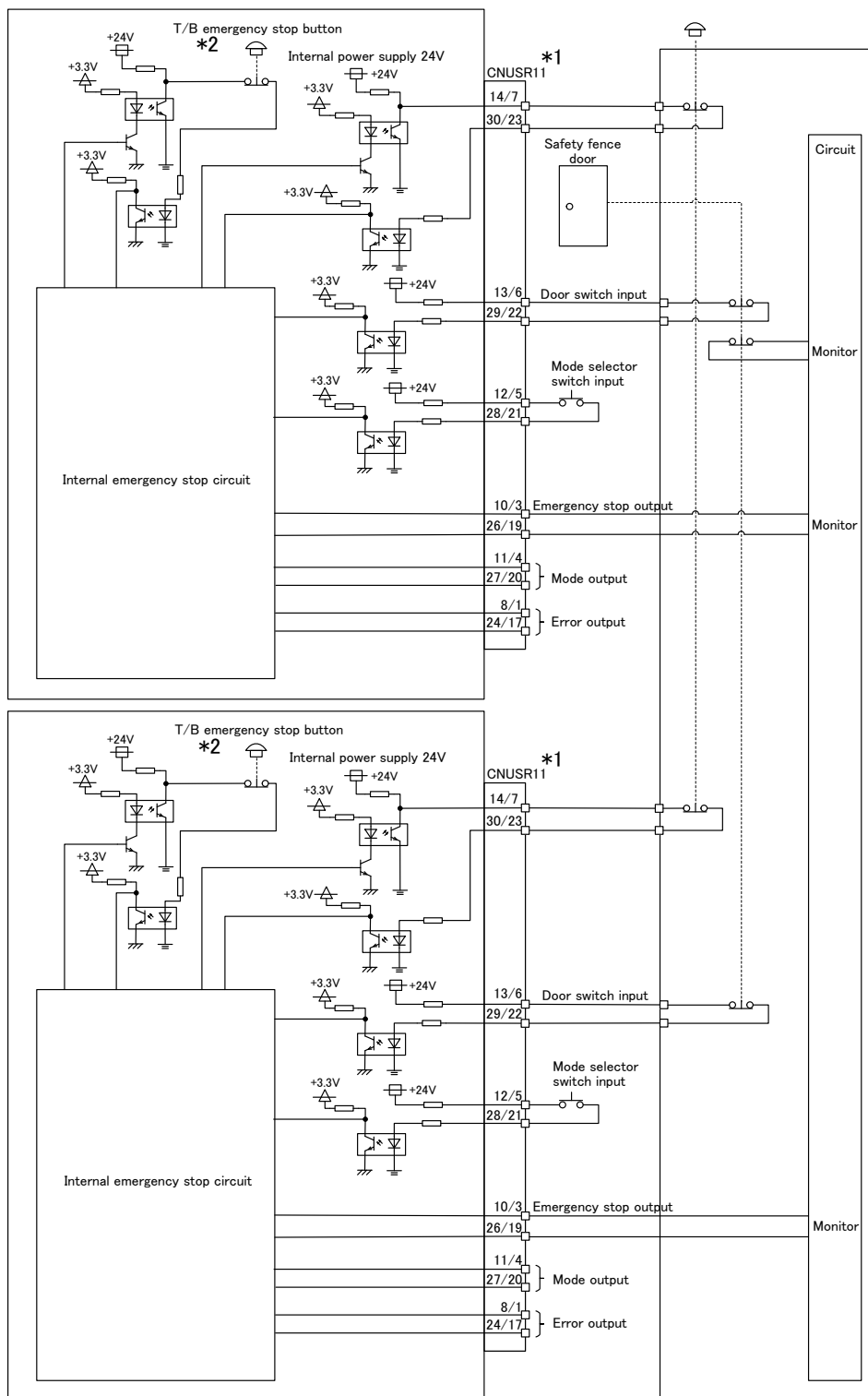

*1) The CNUSR11 connector is a two-level terminal block, indicating that there are two circuits (channels). Two terminals (cable insertion holes) need to be used for one circuit.

*2) The T/B emergency stop button connected with the controller.

Fig.2-14 : Example of safety measures (wiring example 3)

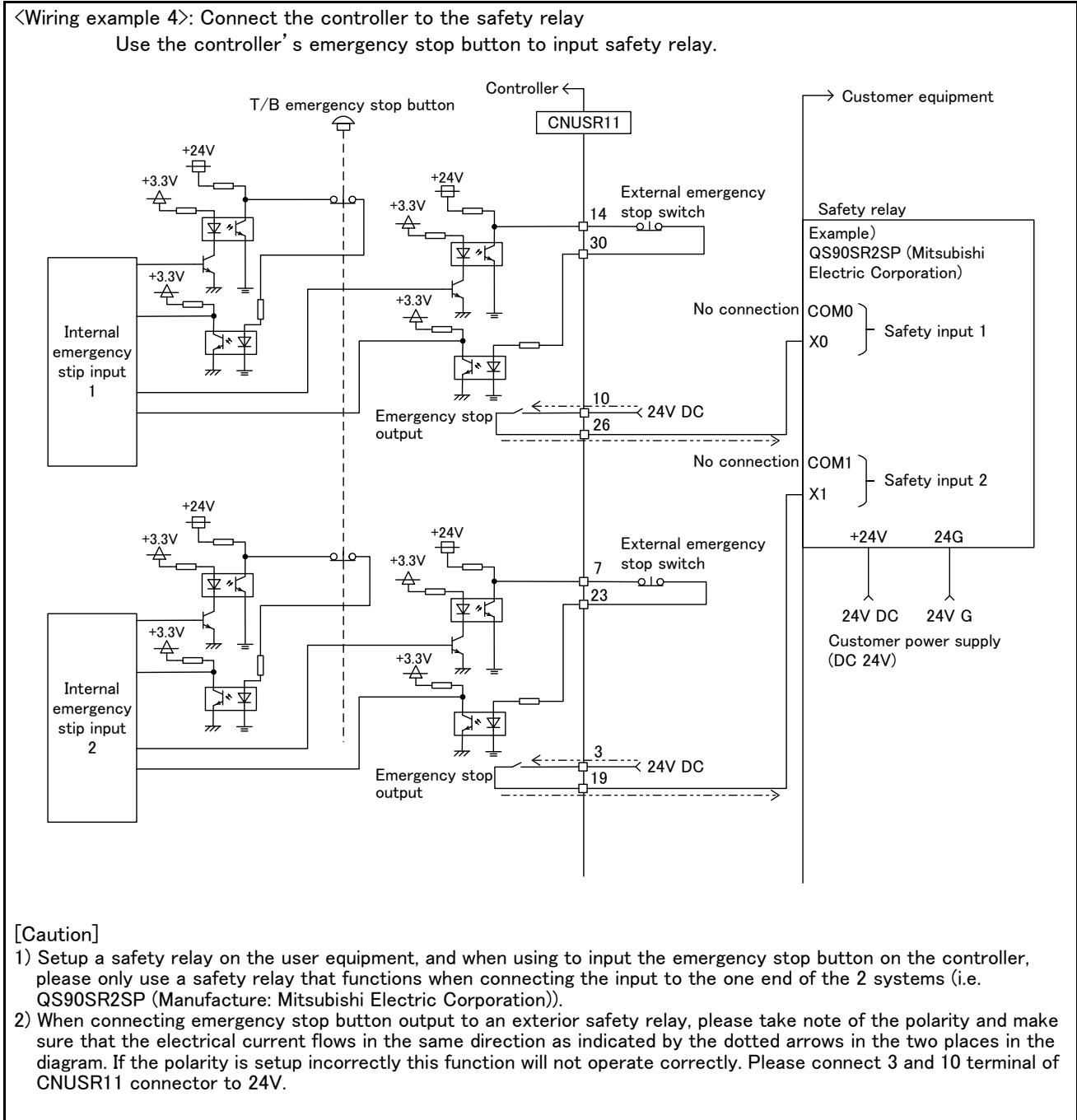

Fig.2-15 : Example of safety measures (wiring example 4)

(1) External emergency stop connection [supplementary explanation]

- (1) Use a 2-contact type switch for all switches.
- (2) Install a limit switch on the safety fence's door. With a constantly open contact (normal open), wire to the door switch input terminal so that the switch turns ON (is conducted) when the door is closed, and turns OFF (is opened) when the door is open.
- (3) Use a manual-return type of normal close which have two lines for the emergency stop button.
- (4) Classify the faults into minor faults (faults that are easily restored and that do not have a great effect) and major faults (faults that cause the entire system to stop immediately, and that require care in restoration), and wire accordingly.

[Caution] The emergency stop input (terminal block) on the user wiring in the controller can be used for safety measures as shown in figure above. Note that there are limits to the No. of switch contacts, capacity and cable length, so refer to the following and install.

- Switch contactPrepare a 2-contact type.*1)
- Switch contact capacityRelated current of 24 VDC or higher for a no-voltage contact. *1)
- Cable length.....The length of the wire between the switch and terminal block must be max. 15m or less. Please use the shield line, in case of the cable may receive the noise etc. by other equipment, such as servo amplifier. And, if it is necessary, please fix a ferrite core (recommended model name: E04SR301334, manufacturer: Seiwa Electric Mfg. Co., Ltd.) to the shielded cable.

The size of the wire that fits to use is shown below.

CNUSR11 connector: AWG24 to 16 (0.2 to 1.25mm²)

Electric specification of the emergency stop related output circuit is 100mA/24V or less. Don't connect the equipment except for this range.

 **CAUTION**

Be sure to perform wiring correctly. If there are mistakes in the wiring, the robot may not stop when the emergency stop button is pressed and there will be a risk of damage or personal injury occurring.

After wiring, be sure to press each of the installed emergency stop switches and check whether the emergency stop circuit works properly.

 **CAUTION**

Be sure to duplicate connection of the emergency stop, door switch and mode selector switch. If not duplicated, these functions may fail due to a broken relay used by customer, etc.

*1) The minimum load electric current of the switch is more than 5mA/24V.

2.3.8 Additional axis synchronization output

When an additional axis is used, the servo ON/OFF status of the additional axis can be synchronized with the servo ON/OFF status of the robot itself by using the output contact (AXMC) provided on the rear or inside of the controller and configuring a circuit so that the power to the servo amplifier for the additional axis can be turned off when this output is open.

An example circuit is shown in Page 36, "(1) Example circuit". An image of how to connect the connector is shown in Page 37, "(2) Image of how to connect the controller connector".

When you are using an additional axis, please perform appropriate circuit connections by referring to these drawings.

Refer to the separate "Additional axis interface Instruction Manual" for details on the additional axis function.

Note1) You use the addition axis function as a user mechanism who became independent of the robot arm, please do not connect this output signal. Servo-on of the user mechanism.

(1) Example circuit

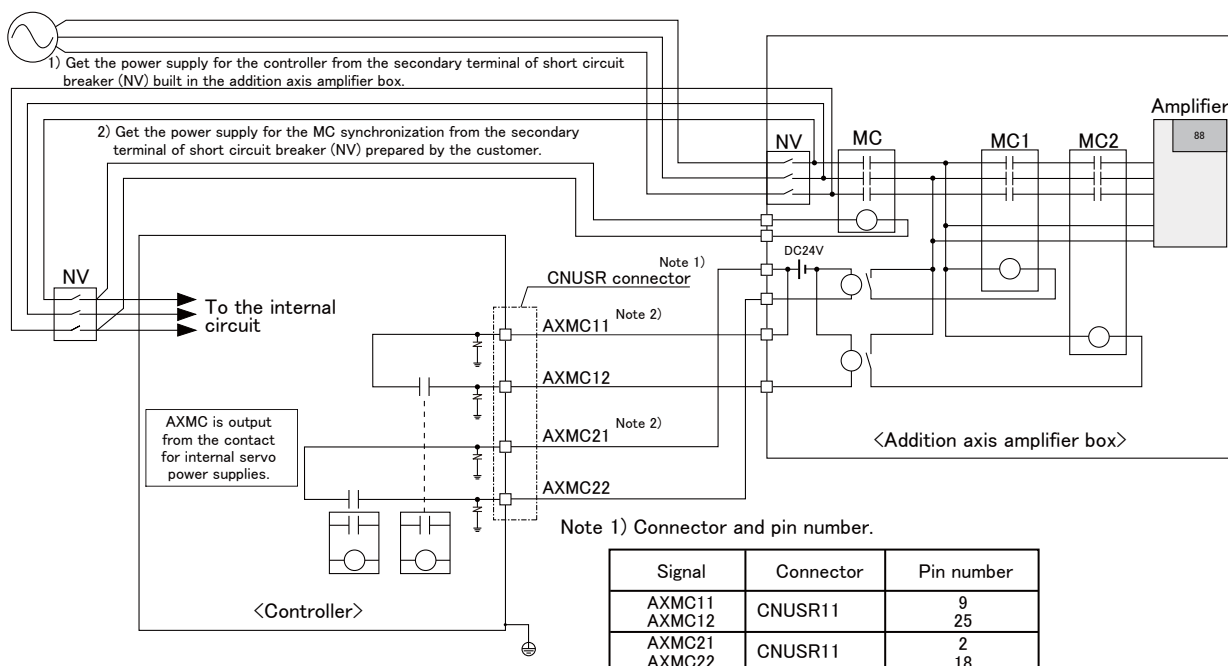

Note 2) This output is opened, if the robot turns off the servo by occurrence of alarm etc.
 <Electric specification>
 DC24V/10mA to 100mA

[Note] For the input/output cable (CNUSR connector cable) that connects customer's system and the controller, prevent ground faults from occurring at the + side of the 24V power supply prepared by customer. A ground fault may lead to a failure of the protection device in the controller.
 Bending or frictional forces may be applied to the input/output cable repeatedly depending on the system configuration or layout. In this case, use a flexible cable for the input/output cable. Note that a fixed cable may be broken, resulting in a ground fault.

Fig. 2-16 : Example of circuit for additional axis synchronization output

(2) Image of how to connect the controller connector

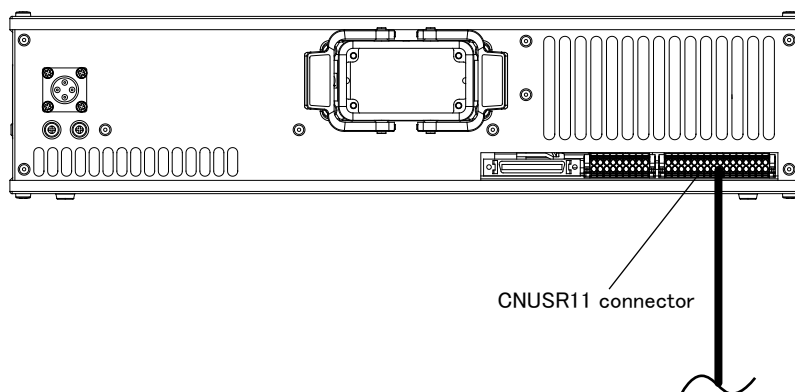

* Refer to [Page 30](#) "Fig. 2-11: Wiring method to the user wiring connector" for more details about how to wire a connector.

Fig. 2-17 : AXMC terminal connector

2.3.9 Connecting to the robot arm

Use a machine cable to connect a robot arm with a controller.

(1) Connecting a machine cable

Refer to the separate manual "Robot arm setup and maintenance", and connect the controller and robot arm with machine cables.

(2) Removing a machine cable

When removing the machine cable from a controller, push the fixation hook of the machine cable connector and unlock the connector.

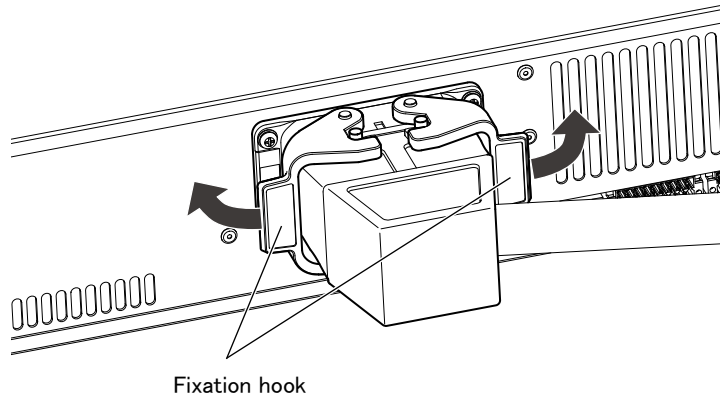

If the fixation hook is too stuck to release the connector, use a flathead screwdriver to release the connector as shown below.

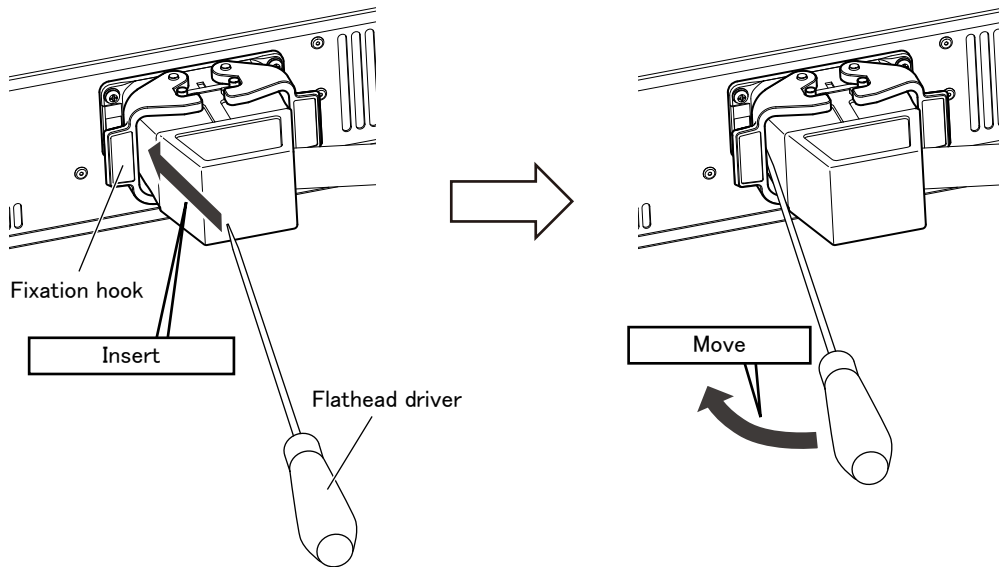

[Note]

A flathead driver will possibly damage the connector and fixation hook by scratching it. Please use a waste cloth to prevent damage to the connector and fixation hook.

2.4 Confirming the operation

Refer to the separate manual "Robot arm setup and maintenance", and confirm the robot operation with jog operation.

3 Installing the option devices

Refer to [Page 47, "4.2.1 Installing and removing the T/B"](#) for installing method of T/B. Refer to the separate "Standard Specifications" or each option's manual for the optional devices other than those described in this manual.

3.1 Installing/removing the Option Card

CAUTION When installing or removing the interface card, it is required to keep the interface card in parallel with the controller.

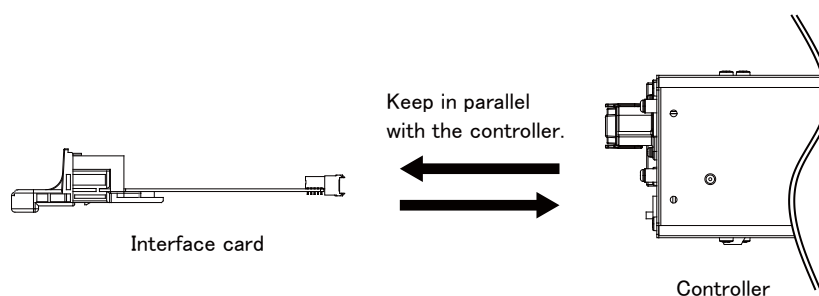

3.1.1 Installing the Option Card

The following describes where and how to install the interface card.

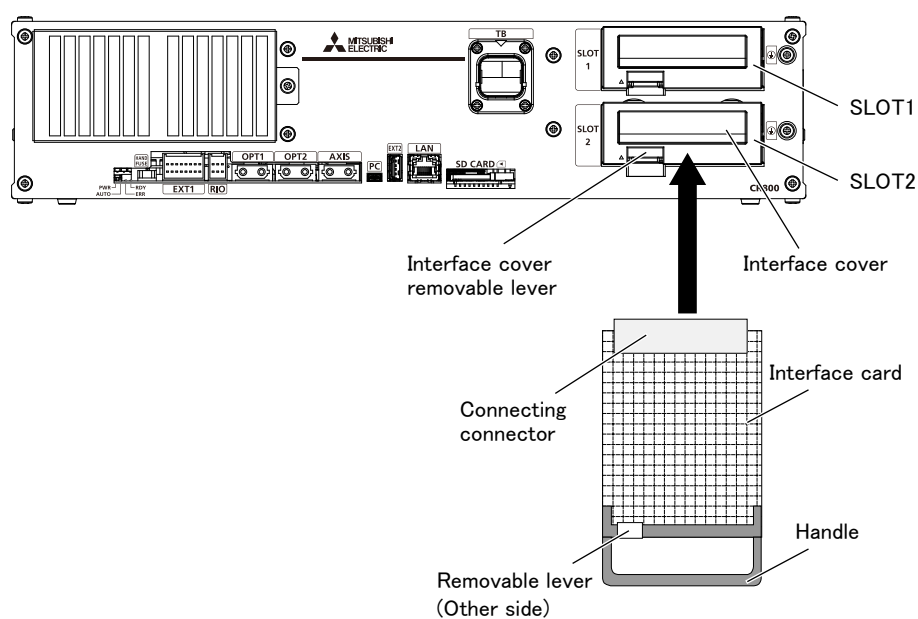

Fig. 3-1 : Installation of the interface card

- 1) Turn off the power.
- 2) Pick the interface cover removal lever and pull up the interface cover.
- 3) Insert the interface card in SLOT1 or SLOT2.
Insert the card as both ends of the card may fit into the guide of slot (SLOT1 or SLOT2 showed in [Fig. 3-1](#)).
- 4) Insert the connection connector securely to the back until the removal lever is locked with the sound.

The installation of the interface card is completed.

3.1.2 Removing the Option Card

The following describes how to remove the interface card.

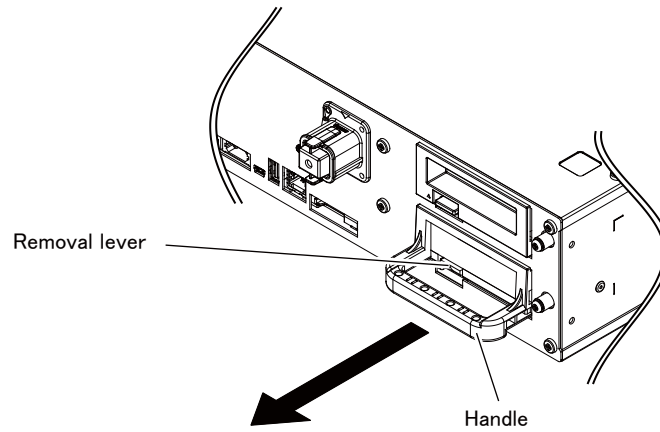

Fig. 3-2 : Removing of the interface card

- 1) Turn off the power.
- 2) Remove the interface card with the removal lever pushed up. Hold the handle of the interface card and pull out the interface card in parallel with the controller.

The removing of the interface card is completed.

3.2 Installing and wiring of the controller protection box (CR800-MB)

Method of installing and wiring with CR800-MB is as follows.

- 1) Release the metal fittings (4 pcs.) of CR800-MB and remove the top plate.
- 2) Copy the serial number of a controller to a transcription label, and put it to the front of CR800-MB. After that, put a transparent label on to a transcription label.
- 3) Remove the fixing plate (screw x 4pcs.) in CR800-MB (left side), fix it to the left side of a controller by 4 screws (attached).
- 4) Connect the power supply terminal of the ACIN cable (controller attachment parts) to the terminal base of CR800-MB. And connect the FG terminal of the ACIN cable to the earth terminal of CR800-MB.
- 5) Put a controller into CR800-MB and fix it by 4 screws which are removed in process "3)".
- 6) Connect the ACIN cable to the ACIN connector on the backside of a controller. And store the ACIN cable in the bottom space of CR800-MB.

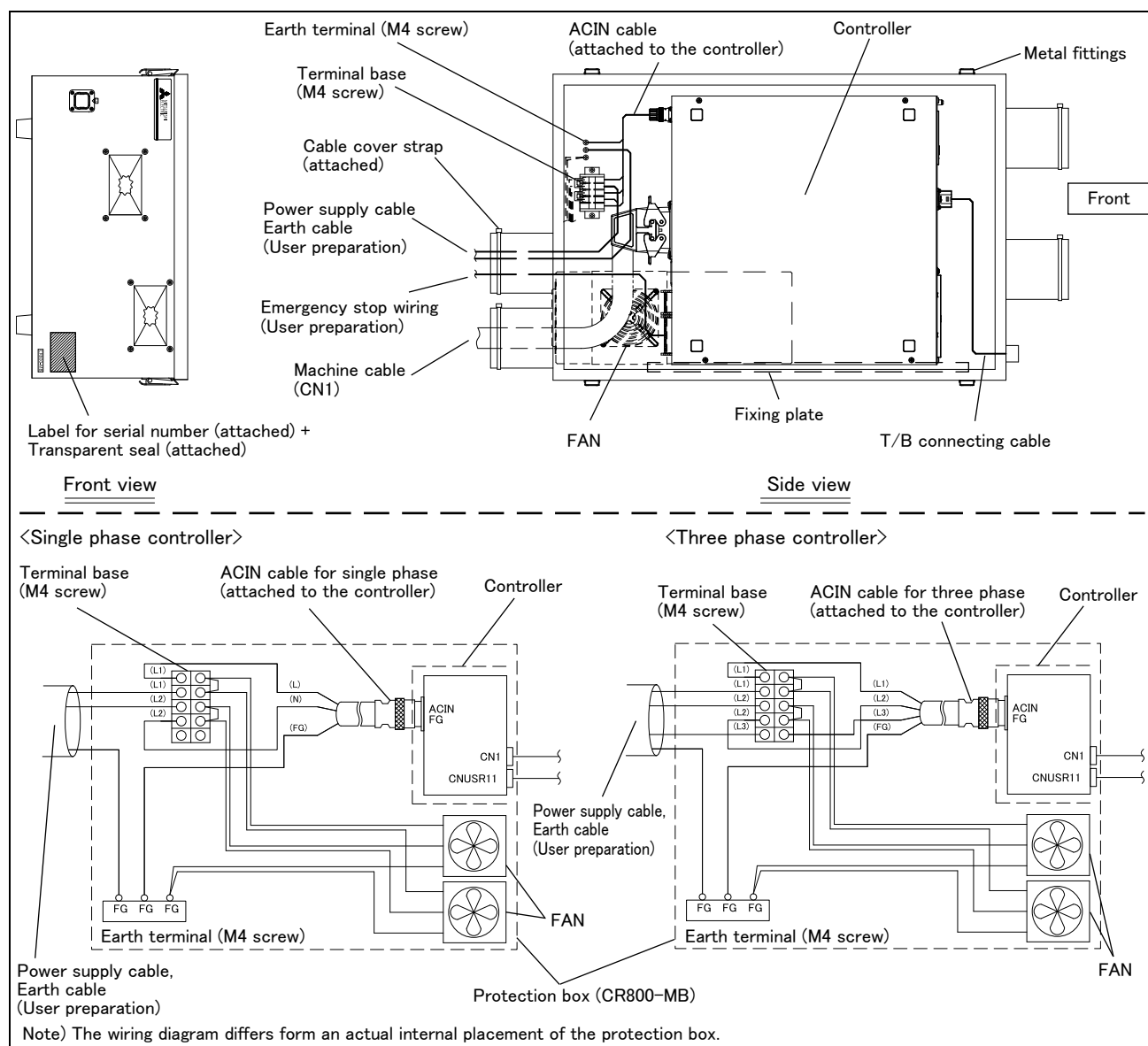

Fig. 3-3 : Internal structure and wiring diagram

- 7) Prepare a power supply cable and an earth cable, and connect them to the terminal base and the earth terminal in CR800-MB.
- 8) For safety, absolutely prepare an external emergency stop equipment. Refer to [Page 25, "2.3.6 Connecting the external emergency stop and mode selector switch"](#) for connecting the external emergency stop.
- 9) Connect the machine cable to a controller and package all the cable covers with cable ties (attached).
- 10) Connect T/B connecting cable installed in the front inside of CR800-MB to T/B connector of a controller.

11) Fix the top plate with metal fittings (4 pcs.) of CR800-MB.

⚠ CAUTION When you do not connect T/B to CR800-MB, be sure to connect T/B cap to TB connector.

⚠ CAUTION Install a controller option before combining a controller and CR800-MB.

⚠ CAUTION When CR800-MB is used vertically, exchange for the screws of the left side the rubber legs attached to the bottom.

⚠ CAUTION Always transport CR800-MB by two people or more. (Mass of CR800-MB: 20kg)

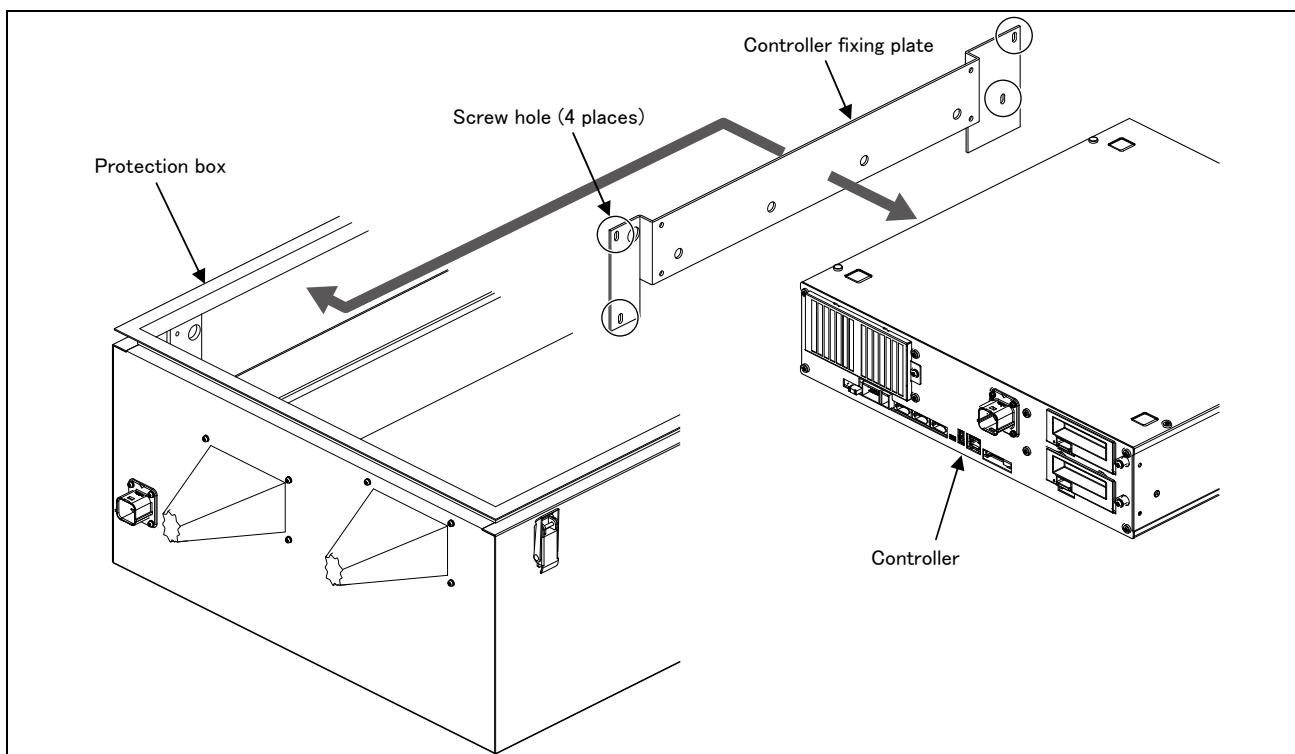

Fig. 3-4 : Controller installation drawing

Installing and wiring of CR800-MB is completed.

4 Basic operations

In this chapter, the following items will be explained regarding the basic operations for handling the robot.

Handling the controller

The functions of the various keys on the controller are explained.

Handling the teaching pendant

The methods of installing/removing the T/B, and the functions of the various keys are explained.

Turning the power ON/OFF

The items to confirm before turning on the controller power, and the methods of turning the power ON and OFF are explained.

Operating the robot with jog operation

The methods for manually operating the robot arm using the teaching pendant are explained. This is mainly used for teaching work.

Opening and closing the hand

The methods of opening and closing the hand using the teaching pendant are explained.

Program creation to automatic operation

The procedures of creating the program are explained in order.

4.1 Handling the controller

4.1.1 Names of each parts

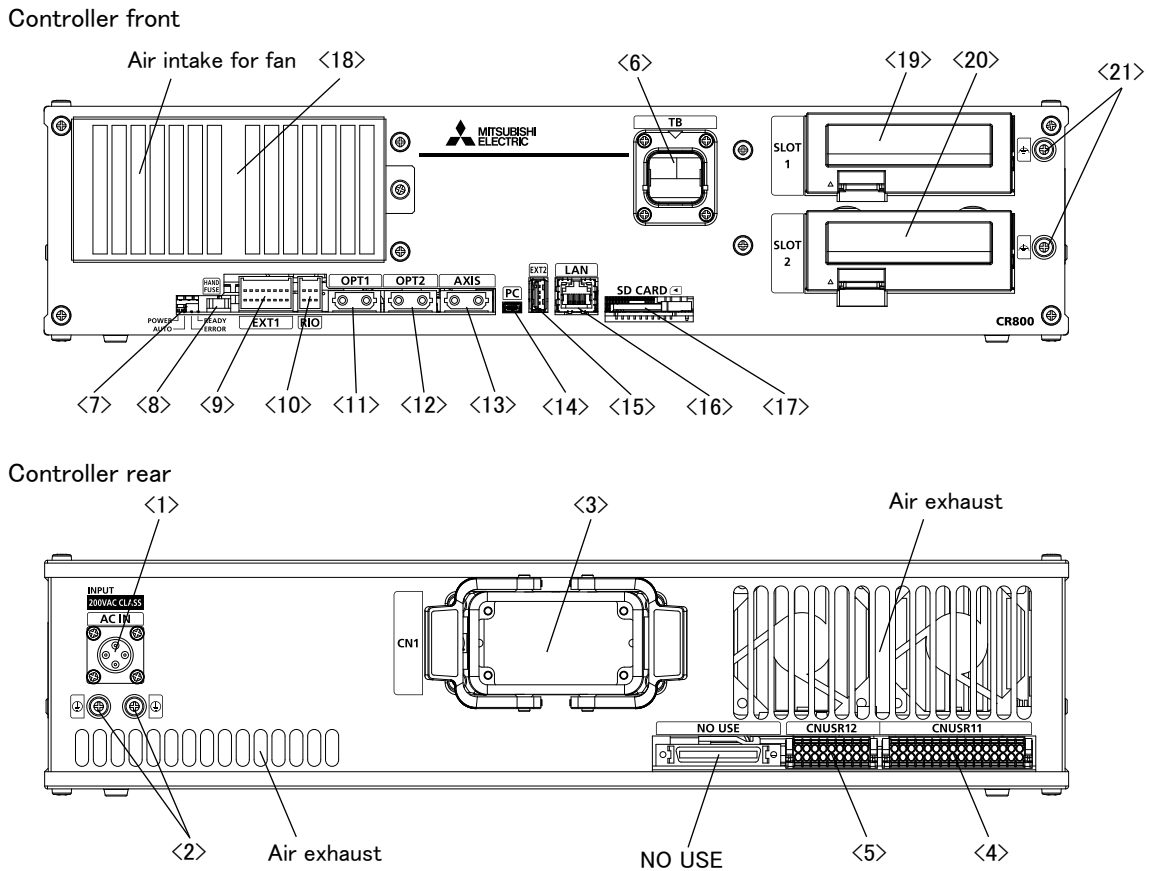

Fig. 4-1 : Names of controller parts

<1> ACIN connector Supplied ACIN cable connector (input voltage: AC200V).

Number of phase	ACIN cable
Single phase	<p>L (Black) N (White) FG (Green)</p> <p>Terminal: M5, cable length: 3m</p>
Three phase	<p>L1 (Black) L2 (White) L3 (Red) FG (Green)</p> <p>Terminal: M5, cable length: 3m</p>

<2> PE terminal Terminals for grounding (M4 screw x 2).

<3> CN1 cable Machine cable connector.

<4> <5> CNUSR connector Robot I/O cable connectors.

<4>: CNUSR11, <5>: CNUSR12

<6> TB connector Dedicated connector for connecting T/B.

<7> LED Four LEDs indicating the controller status.

LED	Details
POWER	Indicates the control power status. On: Control power ON Off: Control power OFF
AUTO	Indicates the controller mode. On: AUTOMATIC mode Off: MANUAL mode
ERROR	Indicates the error status. On: Error occurred. Rapid flashing: High-level error occurred. Off: Normal operation
READY	Indicates the operation status. On: ON (ready) Slow flashing: During operation Rapid flashing: Operation suspended.

<8> HAND FUSE Fuse for the hand.

<9> EXT1 Connector for releasing the brake in an emergency.
For details on the method of releasing the brake in an emergency, refer to the separate manual, "INSTRUCTION MANUAL/ROBOT ARM SETUP & MAINTENANCE".

<10> RIO Parallel I/O extension connector.

<11> OPT1 Connector for communication with the robot CPU. This connector cannot be used in CR800-D controller.

<12> OPT2 Unused.

<13> AXIS Connector for additional axis connection.

<14> PC Connector for communication with a personal computer. This connector cannot be used in CR800-R/CR800-Q controller.

<15> EXT2 Connector for function extension. This connector cannot be used in CR800-R/CR800-Q controller.

<16> LAN Connector for Ethernet communication. This connector cannot be used in CR800-R/CR800-Q controller.

<17> SD CARD SD memory card slot. This connector cannot be used in CR800-R/CR800-Q controller.

<18> Filter cover Dustproof dust filter cover. An air filter is provided inside the filter cover.

<19> <20> Option slot Option card slots (must be covered when not used).

<19> SLOT1, <20> SLOT2

<21> FG terminal Option card cable terminals for grounding (M4 screw x 2).

CAUTION

Use the network equipments (personal computer, USB hub, LAN hub, etc) confirmed by manufacturer. The thing unsuitable for the FA environment (related with conformity, temperature or noise) exists in the equipments connected to USB. When using network equipment, measures against the noise, such as measures against EMI and the addition of the ferrite core, may be necessary. Please fully confirm the operation by customer. Guarantee and maintenance of the equipment on the market (usual office automation equipment) cannot be performed.

CAUTION

For USB connection between the RT ToolBox3 and the robot controller, noise may cause the instability in data communication.
As a solution, switching communication method to LAN connection is recommended.

◆◆◆ What are the operation rights? ◆◆◆

Even when multiple devices, such as a T/B and personal computer, are connected to the controller, the operation at one time is limited to one device. This limited device (has the operation rights)

◆◆◆ What operations require the operation rights? ◆◆◆

Operations that start the robot, such as program start and alarm reset, and operations that can cause starting require the operation rights. Conversely, operation that stop the robot, such as stopping and servo OFF, can be used without the operation rights for safety purposes. Refer to the separate manual "Explanation of functions and operations" for details on the functions related to operation rights.

4.2 Handling the T/B

4.2.1 Installing and removing the T/B

Installing and removing the T/B, with turning off the controller power. If T/B is installed and removed in the state of control source ON, emergency stop alarm will be occurred.

However, it allows you to remove the T/B from the controller without occurrence of alarm by pulling out the T/B connector within five seconds while the 3-position enable switch of the T/B is being pulled up lightly (in the position 2).



CAUTION

Please do not pull the cable of T/B strongly or do not bend it too much.

It becomes the breaking of a wire of the cable and the cause of breakage of the connector. Please installing and removing so that stress does not start the cable with the connector itself.

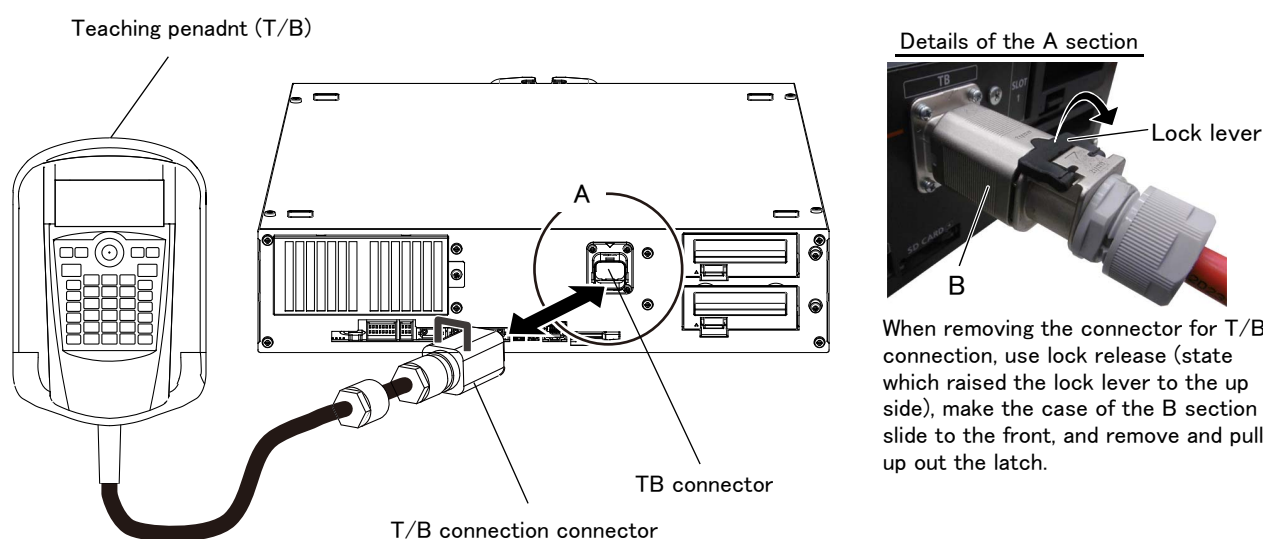

Fig. 4-2 : Installing and removing the T/B

(1) Installing the T/B

Explain the installation method of T/B below.

- 1) Check that the power supply of the robot controller is OFF.
- 2) Refer to Fig. 4-2, connects T/B connector to the robot controller. Use as the upper surface the lock lever, and push in until there is sound.

The installation of T/B is finished.

(2) Removing the T/B

Explain the removing method of T/B below.

■ In MANUAL mode

- 1) Check that the power supply of the robot controller is OFF.
- 2) Refer to Fig. 4-2, raise up the lock lever in the connector upper part, and pull up the connector. Please install the dummy connector, if you use the robot, without connecting T/B.

The removing of T/B is finished.

■ In AUTOMATIC mode

- 1) Pull up lightly (in the position 2) the 3-position enable switch of the T/B.
- 2) Pull out the T/B connector within five seconds while 1). Refer to Fig. 4-2, raise up the lock lever in the connector upper part, and pull up the connector. Please install the dummy connector, if you use the robot, without connecting T/B.

The removing of T/B is finished.

4.2.2 Functions of each key



Fig. 4-3 : Teaching pendant

- ① [Emergency stop] switch.....The robot servo turns OFF and the operation stops immediately. The release of the emergency stop turns the switch to the right, or pulls it.
- ② [Enable/Disable] switch.....This switch changes the T/B key operation between enable and disable.
- ③ [Enable] switch.....When the [Enable/Disable] switch is available, the servo will be turned off, if this switch is release or it pushes strongly. And the robot will stop immediately.
- ④ LCD display panel.....The robot status and various menus are displayed.
- ⑤ Status display lamp.....Display the state of the robot or T/B.
- ⑥ [F1], [F2], [F3], [F4].....Execute the function corresponding to each function currently displayed on LCD.
- ⑦ [FUNCTION].....Change the function display of LCD.
- ⑧ [STOP] keyThis stops the program and decelerates the robot to a stop.
- ⑨ [OVRD ↑][OVRD ↓] key.....Change moving speed. Speed goes up by [OVRD ↑] key. Speed goes down by [OVRD ↓] key
- ⑩ [JOG] operation keyMove the robot according to jog mode. And, input the numerical value.
- ⑪ [SERVO] keyPress this key with holding AA key lightly, then servo power will turn on.
- ⑫ [MONITOR] key.....It becomes monitor mode and display the monitor menu.
- ⑬ [JOG] keyIt becomes jog mode and display the jog operation.
- ⑭ [HAND] keyIt becomes hand mode and display the hand operation.
- ⑮ [CHAR] keyThis changes the edit screen, and changes between numbers and alphabetic characters.
- ⑯ [RESET] keyThis resets the error. The program reset will execute, if this key and the EXE key are pressed.
- ⑰ [↑][↓][←][→] key.....Moves the cursor each direction .
- ⑱ [CLEAR] key.....Erase the one character on the cursor position .
- ⑲ [EXE] keyInput operation is fixed. And, while pressing this key, the robot moves when direct mode.
- ⑳ Number/Character keyErase the one character on the cursor position . And, inputs the number or character

◆◆◆ Remove the protection seal of the teaching pendant before using ◆◆◆
 Installed the protection seal on the teaching pendant to prevent the damage of the display LCD and the key seat when shipping. Remove the protection seal when using. The operation of the key and the confirmation of the display is possible without removing the protection seal, however the adhesive may be left on the teaching pendant as the time passes.

4.3 Turning the power ON and OFF

4.3.1 Turning the control power ON



CAUTION

Always confirm the following items before turning the controller power ON.

- 1) Make sure that there are no operators in the robot operation range.
- 2) Make sure that the controller and robot arm are securely connected with the machine cable.
- 3) Make sure that the external emergency stop switch is connected to the controller.
- 4) Make sure that the controller power cable and grounding cable are correctly connected.
- 5) Make sure that the grounding cable is connected to the robot arm.
- 6) Make sure that there are no obstacles, such as tools, in the robot operation range.

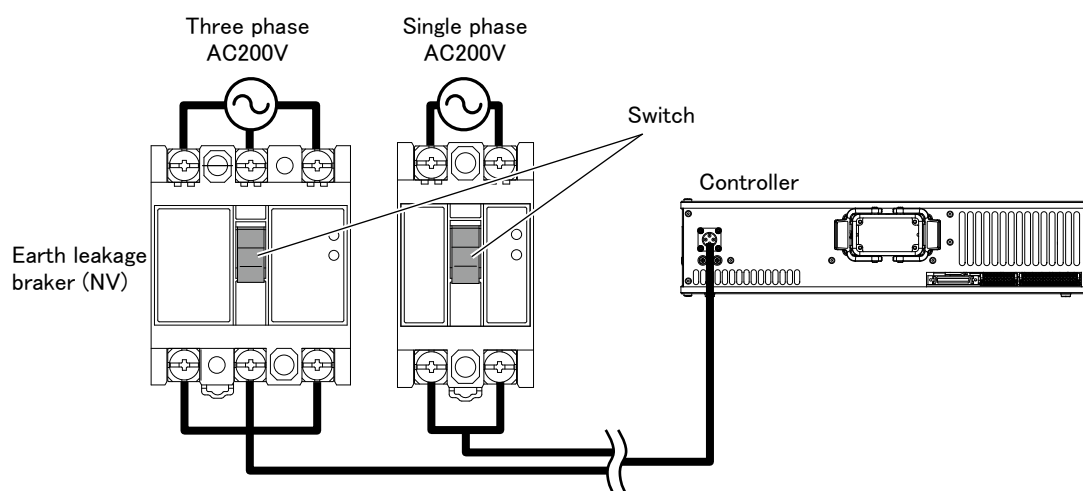

■ CR800-D controller

Operate the earth leakage breaker of installation outside to do the controller's power supply ON/OFF.

Turns ON the switch of the earth leakage breaker of installation outside. The controller power turn on, and the power lamp lights up.

■ CR800-R/CR800-Q controller

Operate the earth leakage breaker of installation outside to do the controller's power supply ON/OFF.

Turns ON the switch of the earth leakage breaker of installation outside. The controller power turn on, and the power lamp lights up Then, the robot CPU unit power on.

4.3.2 Input the serial number

If error C0152 (unmatched robot serial number) occurs after purchasing the robot, please input the serial number of the robot arm into parameter RBSERIAL.

The serial number is printed to the rating name board on base section of the robot arm.

- 1) Press the [RESET] key of T/B and cancel the error of T/B.
- 2) Press the [EXE] key of T/B and display the menu panel.

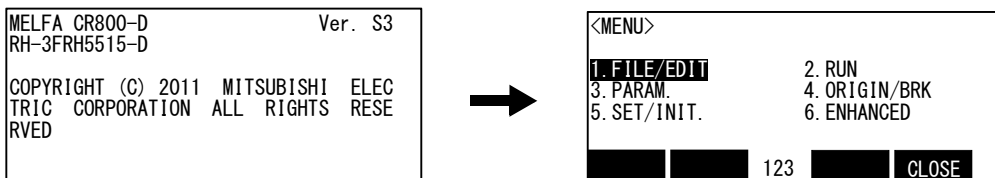

- 3) Press the [3] key of T/B and display the parameter.

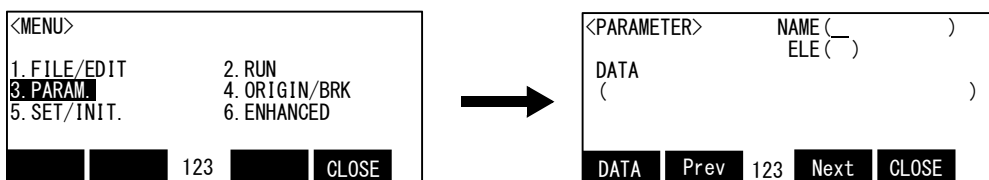

- 4) Input "RBSERIAL" into the name.

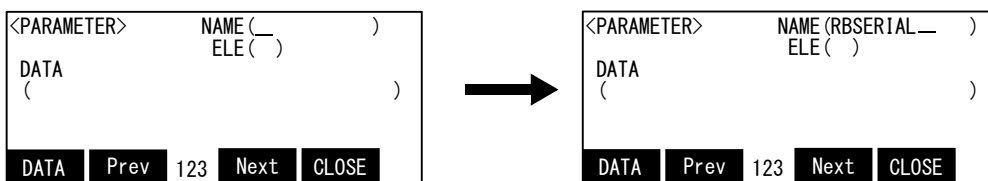

- 5) Press the function key ([F1]) corresponding to the "data", and input the serial number of the robot arm. The serial number stored in the robot arm is automatically displayed.

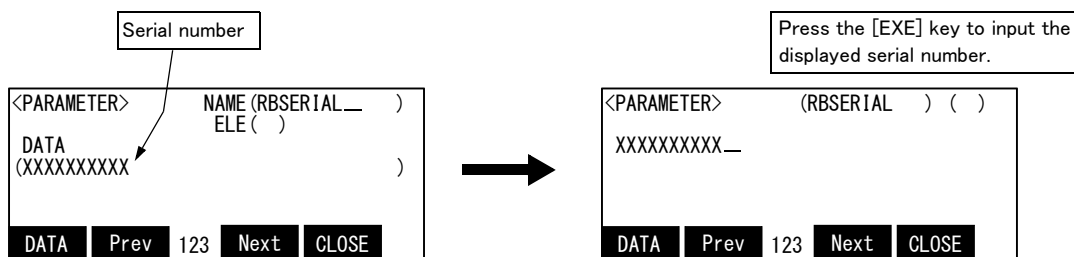

Setting the data [F1]

Execute [EXE]

(Operation will be canceled if the [F4] key is pressed.)

Press the [EXE] key, and fix the value with sound, and return to the parameter screen.

◆◆◆ The input of the number/character ◆◆◆

Each time the [CHARACTER] key is pressed, the number input mode and the character input mode change. The current input mode is displayed in the center under the screen, and the display of "123" shows that the number input mode and "ABC" is the character input mode.

For details, please refer to "INSTRUCTION MANUAL/ Detailed explanations of functions and operations" of the separate volume.

4.3.3 Shutting OFF the control power

■ CR800-D controller

- 1) If the robot is operating, stop the robot.
- 2) After the robot has stopped, turn the servo OFF.
- 3) Turn OFF the switch of the earth leakage breaker installed outside.

■ CR800-R/CR800-Q controller

- 1) If the robot is operating, stop the robot.
- 2) After the robot has stopped, turn the servo OFF.
- 3) Turns off the robot CPU system.
- 4) Turn OFF the switch of the earth leakage breaker installed outside.

4.3.4 Shutting OFF the controller power

If the controller power is shut off while the robot CPU system is ON, the errors shown in [Table 4-1](#) occurs. To recover from the error, reset the error after turning on the controller power. Error resetting operation requires about 60 seconds.

When the robot CPU system was turned off, turn on the robot CPU system after turning on the controller. Refer to [Page 49, "4.3.1 Turning the control power ON"](#) for details.

Table 4-1 : List of errors

Error No.	Error message
H8751	CR800 communication error

4.4 Jog operation

Refer to the separate manual "Robot arm setup and maintenance" when carrying out jog operation. The following jog operation modes are available. Use these according to the purpose.

Table 4-2 : Jog modes

Jog mode	Main application	Explanation
JOINT JOG	<ul style="list-style-type: none"> • Moves each joint. • Moves the robot arm largely. • Changes the robot posture. 	Separate manual "Robot arm setup and maintenance" Separate manual "Detailed explanations of functions and operations"
XYZ JOG	<ul style="list-style-type: none"> • Accurately sets the teaching position. • Moves the axis straight along the XYZ coordinate system. • Moves the axis straight while maintaining the robot posture. • Changes the posture while maintaining the hand position. 	
TOOL JOG	<ul style="list-style-type: none"> • Accurately sets the teaching position. • Moves the axis straight along the hand direction. • Changes the posture while maintaining the hand position. • Rotates the hand while maintaining the hand position. 	
3-AXIS XYZ JOG	<ul style="list-style-type: none"> • When the axis cannot be moved with XYZ JOG that maintains the posture. • When the tip is to be moved linearly but the posture is to be changed. 	
CYLINDER JOG	<ul style="list-style-type: none"> • Moves in a cylindrical shape centering on the Z axis while maintaining the posture. • Moves linearly in a radial shape centering on the Z axis while maintaining the posture. 	
WORK JOG (Work jog mode)	<ul style="list-style-type: none"> • Accurately sets the teaching position. • Moves the axis straight along the coordinates system (work coordinates system) defined in accordance with a workpiece, pallet, etc. • Changes the posture along the work coordinates system. 	
WORK JOG (Ex-T jog mode)	<ul style="list-style-type: none"> • Accurately sets the teaching position. • Moves the axis straight along the work coordinates system (Ex-T coordinates system) defined in accordance with an installed grinder, dispenser, etc. • Changes the posture along the work coordinates system (Ex-T coordinates system). 	

4.5 Opening and closing the hand

Hands 1 to 6 can be opened and closed with the T/B.

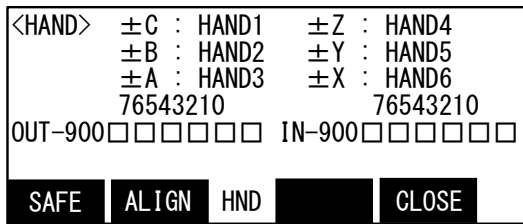

Press the [HAND] key, and display the hand screen.

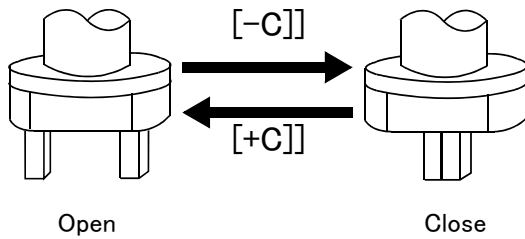

Opening and closing hand 1

Open: Press [+C] key
 Close: Press [-C] key

Opening and closing hand 2

Open: Press [+B] key
 Close: Press [-B] key

Opening and closing hand 3

Open: Press [+A] key
 Close: Press [-A] key

Opening and closing hand 4

Open: Press [+Z] key
 Close: Press [-Z] key

Opening and closing hand 5

Open: Press [+Y] key
 Close: Press [-Y] key

Opening and closing hand 6

Open: Press [+X] key
 Close: Press [-X] key

4.6 Programming

The procedures from creating the program to automatic operation are explained in order using a simple procedure as an example.

MELFA-BASIC VI commands are used in the program examples.

(1) Creation procedures

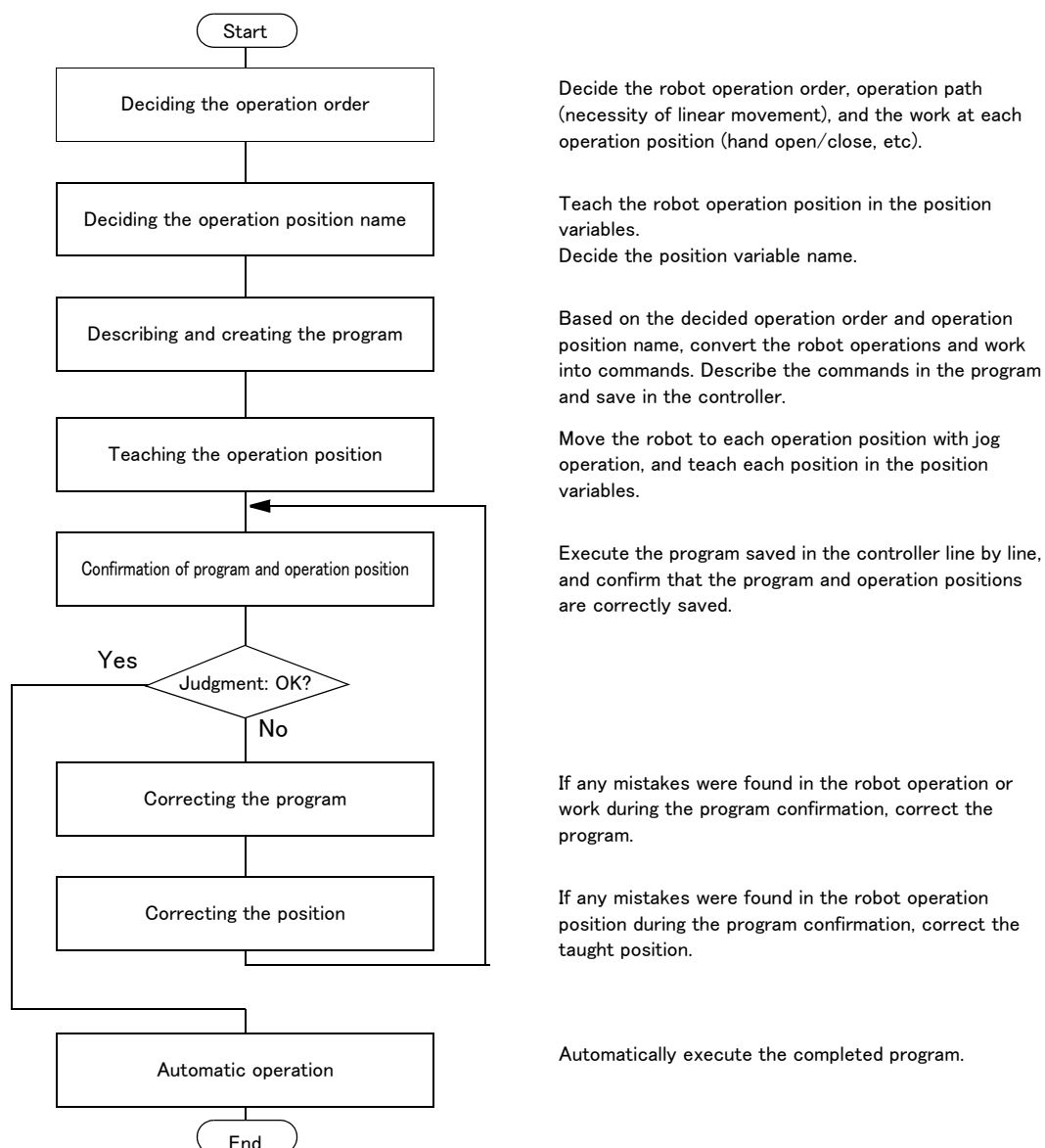

Fig.4-4 : Program creation procedures

(2) Robot work

Assume that the robot is going to carry the workpiece from the left to the right.

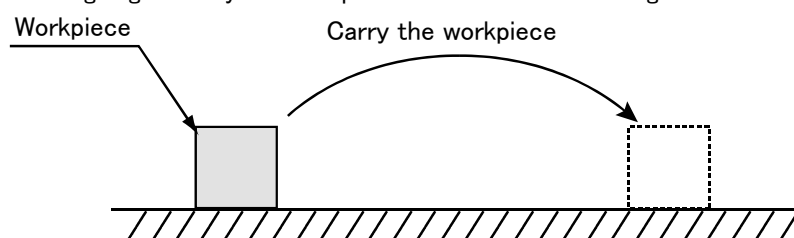
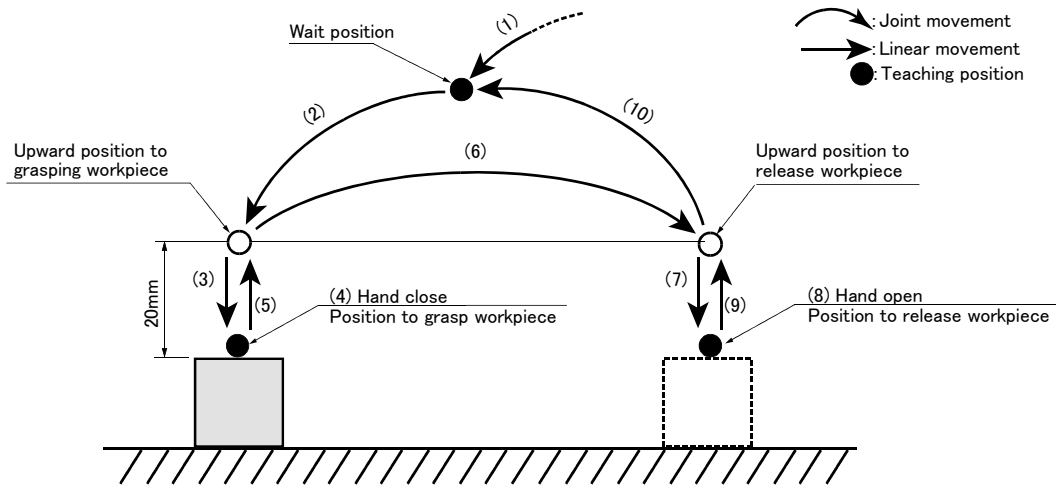

Fig.4-5 : Example of work

4.6.1 Creating the program

(1) Deciding the operation order



Start

- (1) Move to wait position (joint movement).
- (2) Move to 20mm upward workpiece (joint movement).
- (3) Move to position to grasp workpiece (linear movement).
- (4) Grasp workpiece (hand close).
- (5) Move 20mm upward (linear movement).
- (6) Move to 20mm upward position to release workpiece (joint movement).
- (7) Move to position to release workpiece (linear movement).
- (8) Release workpiece (hand open).
- (9) Move 20mm upward (linear movement).
- (10) Move to wait position (joint movement).

End

Fig.4-6 : Deciding the operation order

◆◆◆ Joint movement and linear movement ◆◆◆

The operation for which the robot movement path is not designated in particular is the "joint movement". The operation for which the movement path is designated as linear is "linear movement".

If the robot could interfere with the peripheral devices, such as the workpiece, when moving to grasp or release the workpiece, designate "linear movement" to prevent any interference.

(2) Deciding the operation position name

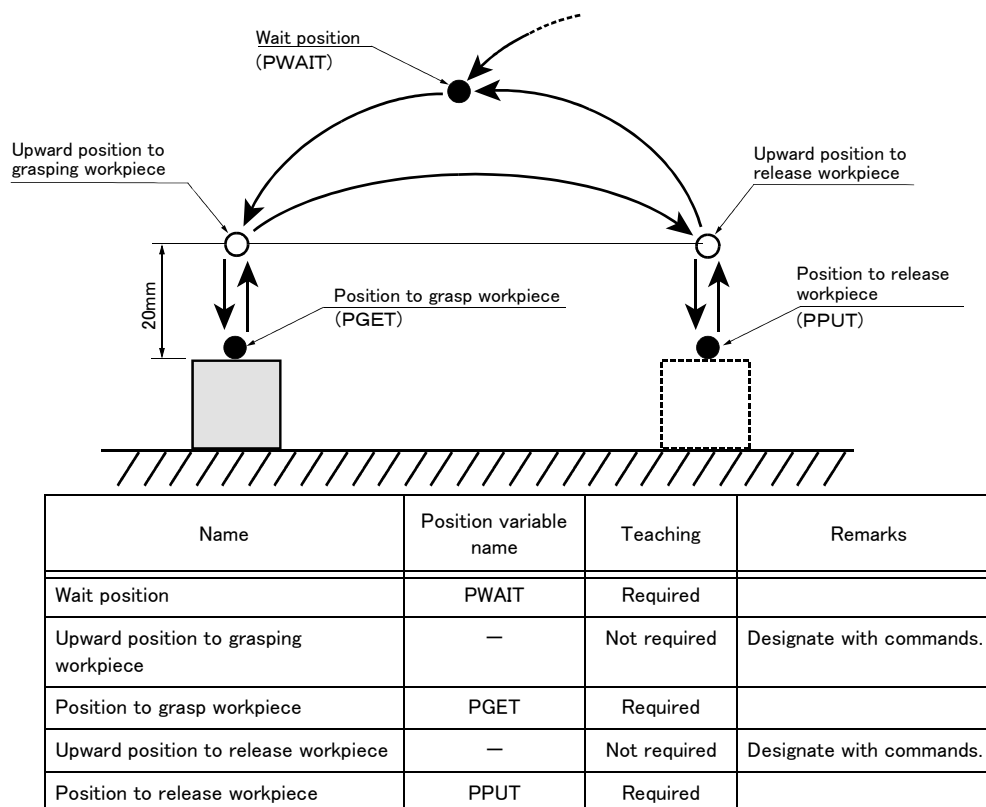

Position variable name ···· Designate a random character string starting with "P".
Up to eight characters can be designated. (For MELFA-BASIC VI commands)

Fig.4-7 : Deciding the operation position name

◆◆◆ Teaching the operation position ◆◆◆

The operation position does not necessarily need to be taught.

The positions shown with white circles in Fig. 4-7 can be designated with commands as "position 20mm away from target position". Refer to Page 58, "(3) Describing and creating the program".

⚠ CAUTION

The designation of the direction separated from the target position differs according to the robot type.

The position is along the Z axis of the TOOL coordinate system, and the direction is designated with the + and - signs.

Refer to the section on the TOOL JOG operation in the separate "Instruction Manual/ Robot arm setup and maintenance", and confirm the Z axis direction of the TOOL coordinate system. Then, designate the correct sign (direction) that matches the robot being used.

Designating the reverse direction could lead to interference with the peripheral devices and damage.

Generally (in the default state), the hand retract direction is the "-" sign with the vertical articulate type robot, and the "+" sign is the robot's upward direction with the other robots.

(3) Describing and creating the program

■ Convert the target robot operations and work into commands.

Refer to the separate manual "Instruction Manual: Detailed explanations of functions and operations" for details on the commands.

Table 4-3 : Commands used (For MELFA-BASIC VI commands)

Target operation and work	Command	Example of designation	
Joint movement	Mov	Move to position variable PWAIT	Mov PWAIT
		Move to 20mm upward position variable PGET	Mov PGET,+20 ^{Note)}
Linear movement	Mvs	Move to position variable PGET	Mvs PGET
		Move to 20mm upward position variable PGET	Mvs PGET,+20 ^{Note)}
Hand open	Hopen	Open hand 1	Hopen 1
Hand close	Hclose	Close hand 1	Hclose 1
Wait	Dly	Wait 1 second	Dly 1.0
End	End	End the program	End

Note) Upward movement is designated at a position along the Z axis of the TOOL coordinate system, and the direction is designated with the + and - signs. Confirm the Z axis direction of the TOOL coordinate system. Then, designate the correct sign (direction) that matches the robot being used. The example of designation above is an example using a horizontal multiple-joint type robot.

■ Program the converted commands

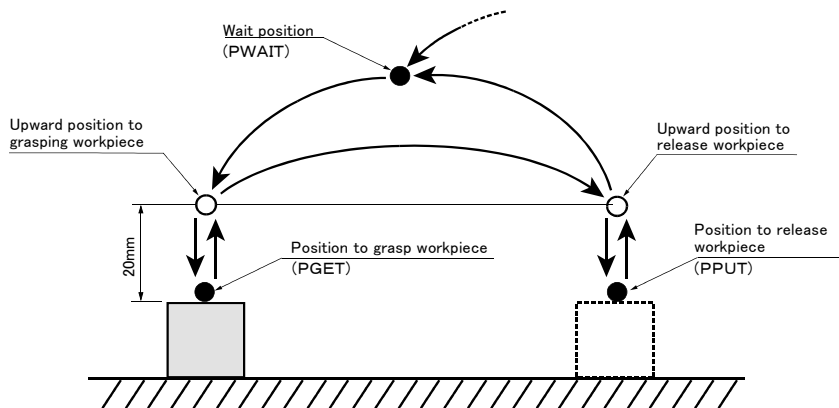

Start

- (1) Move to wait position (joint movement) 1 Mov PWAIT
- (2) Move to 20mm upward workpiece (joint movement)..... 2 Mov PGET,+20 ^{Note)}
- (3) Move to position to grasp workpiece (linear movement)..... 3 MVS PGET
- (4) Grasp workpiece (hand close)..... 4 HClose 1
- (5) Waits for 1 seconds 5 Dly 1.0
- (6) Move 20mm upward (linear movement)..... 6 MVS PGET,+20 ^{Note)}
- (7) Move to 20mm upward position to release workpiece (joint movement) ... 7 Mov PPUT,+20 ^{Note)}
- (8) Move to position to place workpiece (linear movement) 8 MVS PPUT
- (9) Release workpiece (hand open)..... 9 HOpen 1
- (10) Waits for 1 seconds 10 Dly 1.0
- (11) Move 20mm upward (linear movement) 11 MVS PPUT,+20 ^{Note)}
- (12) Move to wait position (joint movement) 12 Mov PWAIT
- End..... 13 End

Hand ···· Up to four hands can be installed. However, in the above program, the 1st hand connected to hand 1 is the target.

Fig. 4-8 : Describing the program

⚠ CAUTION

Note) Upward movement is designated at a position along the Z axis of the TOOL coordinate system, and the direction is designated with the + and – signs. Refer to the section on the TOOL JOG operation in the separate “Installation Manual/ Robot arm setup and maintenance”, and confirm the Z axis direction of the TOOL coordinate system. Then, designate the correct sign (direction) that matches the robot being used.

Designating the reverse direction could lead to interference with the peripheral devices and damage.

Generally (in the default state), the hand retract direction is the “–” sign with the vertical articulate type robot, and the “+” sign is the robot’s upward direction with the other robots. “+20” in the command line is a example in horizontal multiple-jointed type robot.

◆◆◆ Program format ◆◆◆

The program format is configured of the “step No. command parameter affixed to command” as shown in [Fig. 4-8](#).

Example) 1 Mov PWAIT

step No. Command Parameter affixed to command

The program is executed in order from the step No. with the smallest number.

- Input the described program into the controller.
The T/B is used for this operation.

Preparing the T/B

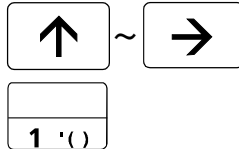
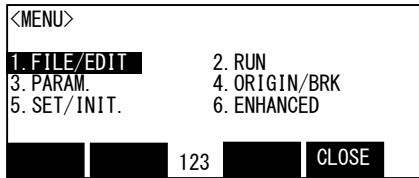
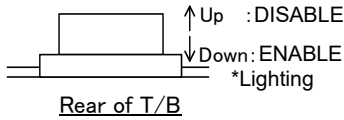

- Set the controller's mode to "MANUAL".
- Set the T/B [ENABLE] switch to "ENABLE".

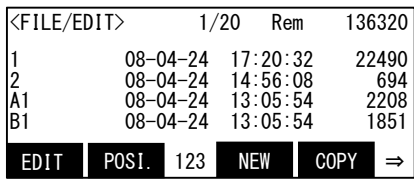

- In the <MENU> screen, press the arrow keys ("↑", "↓", "←", "→") and move the cursor to "1. Management and edit", and then press the [EXE] key. The <Management and edit> screen will appear.

- Press the [F3](New) key, and display the new program screen.

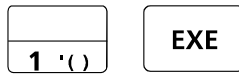
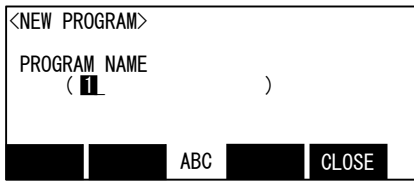

- Press [1], [EXE] key, and display the edit screen of program No1.



◆◆◆ Using the T/B ◆◆◆

Set the controller's mode to "MANUAL" and the T/B [ENABLE] switch to "ENABLE". While the T/B is enabled, you can only use the T/B to command operations. The external signals cannot be used to command operations.

◆◆◆ Inputting numbers ◆◆◆

Each time the [CHARACTER] key is pressed, the number input mode and the character input mode change. The current input mode is displayed in the center under the screen, and the display of "123" shows that the number input mode. The number currently written to the lower left of each key in this state can be inputted.

◆◆◆ Correcting incorrect numbers ◆◆◆

Press the [CLREAR] key to delete the character, and then input it again. And, if the long pushing [CLEAR] key, all the data in the parenthesis can be deleted.

If the cursor is returned by pressing the [←] key, and a character is input, it will be inserted.

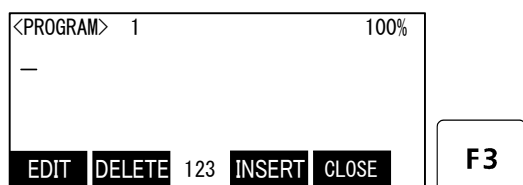

6) Press the [F3] key.
The cursor will move to the command editing line.

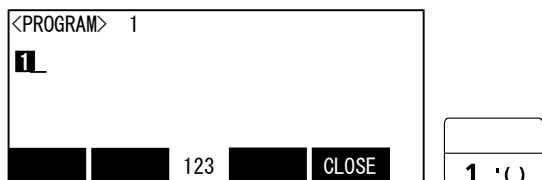

7) Confirm that the number input mode and press the [1] key.
"1" of the step number is inputted.

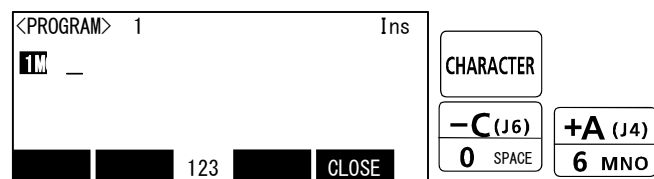

8) Press the [CHARACTER] key, and set to the character input mode, then press [SP], [MNO] key. Display the space and "M."

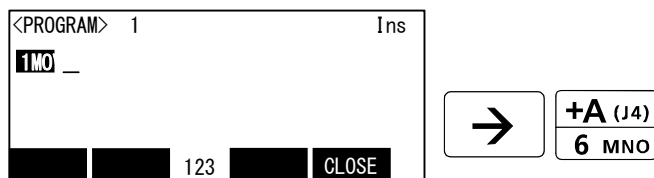

9) Press the [→] key, and the cursor is moved. Then press the [MNO] key 3 times, and input "o".

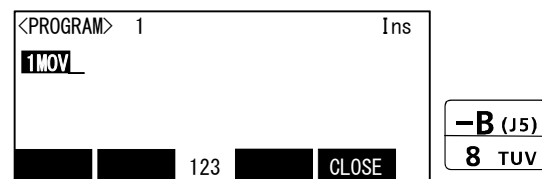

10) Press the [TUV] key 3 times, and input "v".

◆◆◆ Inputting characters and space ◆◆◆

Each time the [CHARACTER] key is pressed, the number input mode and the character input mode change. The current input mode is displayed in the center under the screen, and the display of "ABC" shows that the character input mode. The character currently written to the lower right of each key in this state can be inputted. When you continue and input the character in the same key, once press the [->] key and advance the cursor. The space is assigned to the [SP] key.

◆◆◆ The input method of the mark ◆◆◆

It comes out to input the character which is not displayed on the key. The character currently assigned to the key is shown below.

- a) [' ()] key ' → (→) → " → ^ → : → ; → ¥ → ?
- b) [@ =] key @ → = → + → - → * → / → < → >
- c) [, %] key , → % → # → \$ → ! → & → _ → .

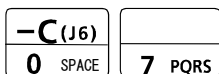

11) Press the [SP], [PQRS] key, and input the space and "P".

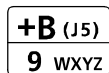

12) Press the [WXYZ] key, and input the space and "W".

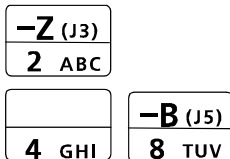

13) Input "A", "I" and "T" in the same manner.

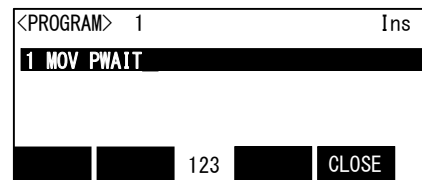

14) Press the [EXE] key.
"1 Mov PWAIT" will be set.

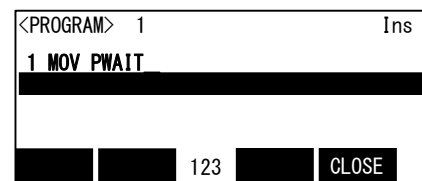

15) Input the program from step 2 to line 13 in the same manner.

The inputting of the program is completed.

◆◆◆ Displaying the previous and next command step ◆◆◆
 Display the four lines on the screen of T/B. For moving the cursor to the front line, the [↑] key is pressed, for moving the cursor to the next line, press the [↓] key, and select.

◆◆◆ Displaying a specific line ◆◆◆
 Press the [FUNCTION] key, and change the function display, and press the [F2] key. The display changes to the JUNP screen. The specification line can be displayed, if the step number to display in the parenthesis is inputted and the [EXE] key is pressed.

■ Teach the robot operation position.

Set the position with jog operation (Teaching PGET)

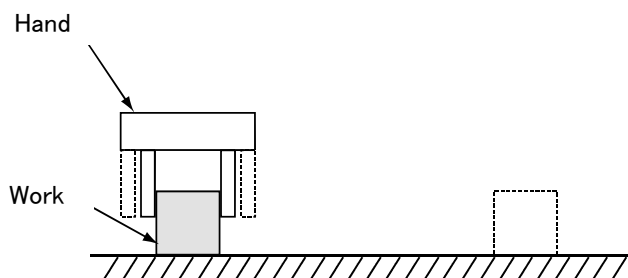

1) Move the robot with jog operation, and set the end of the hand to the position for grasping the workpiece. When the position has been set, open and close the hand to confirm that the workpiece can be grasped.

Refer to [Page 53, "4.4 Jog operation"](#) for details on the jog operation, and section [Page 54, "4.5 Opening and closing the hand"](#) for details on opening and closing the hand.

◆◆◆ Effective use of jog mode ◆◆◆

When the robot's current position is greatly separate from the target position, move the robot in axis units with the "JOINT JOG mode", to approach the position.

If the target position is nearby, move linearly with the "XYZ JOG mode", and finely adjust the position. The position can be set accurately by delaying the override (operation speed) at this time.

<PROGRAM> 1				Ins	
10	Dly	1.0			
11	Mvs	PPUT, +20			
12	Mov	PWAIT			
13	End				
EDIT	DELETE	123	INSERT	CLOSE	
FWD	JUMP	123		BWD	
DIRECT	CHANGE	123		CLOSE	

[FUNCTION] key

FUNCTION	F2
----------	----

<POS.>				JNT 100% PGET	
X:	+128.56	A:	+180.00		
Y:	+0.00	B:	+90.00		
Z:	+845.23	C:	-180.00		
L1:		L2:			
FL1:	7	FL2:	0		
MOVE	TEACH	123	Prev	Next	⇒

F3	F4
----	----

<PROGRAM> 1			
PGET			
RECORD CURRENT POSITION.			
OK?			
Yes		123	No

F1

<POS.>				JNT 100% PPUT	
X:	+128.56	A:	+180.00		
Y:	+0.00	B:	+90.00		
Z:	+845.23	C:	-180.00		
L1:		L2:			
FL1:	7	FL2:	0		
MOVE	TEACH	123	Prev	Next	⇒

2) In the program edit screen, press the [FUNCTION] key twice and change the function display. [F2](change) Press the key and display the position edit screen.

3) Press the [F3](Next) or the [F4](Prev) key, and display "PGET" on the screen upper right. The current registration coordinate value of the position variable name PGET is displayed.

4) Press the [F2] (teaching) key. The teaching confirmation screen is displayed.

5) Press the [F1] (being) key and register the position.

6) Teach PPUT (position to place workpiece) and PWAIT (wait position) in the same manner.

Teaching of the robot operation positions is completed.

◆◆◆ Changing between the command editing screen and position editing screen. ◆◆◆

The commands are edited on the command editing screen, and the positions are edited on the position editing screen.

To change from the command editing screen to the position editing screen, press the [F3] (Change) keys.

To change from the position editing screen to the command editing screen, press the [F2] (Change) keys.

To change the screen, use the [FUNCTION] keys.

(4) Confirming the program

Using the T/B execute the program line by line (step operation), and confirm the operation. Following operations are operated with lightly pressing the enabling switch on the T/B.

1) Press the [FUNCTION] key and change the function display. Press the [F3](change) and display the command edit screen.

2) Press the [FUNCTION] key and change the function display. Pressing the [F1] (FWD) key is kept, and the robot will start moving.

When the execution of one line is completed, the robot will stop, and the next line will appear on the screen. If [F1] (FWD) is released during this step, the robot will stop.

3) By the same operation as the above-mentioned, carry out step operation to the END command of the 13 lines, and confirm movement.

If movement of the robot and the position are wrong, correct with reference to the following operations.

CAUTION

Take special care to the robot movements during operation. If any abnormality occurs, such as interference with the peripheral devices, release the [F1] (FWD) key and stop the robot.

◆◆◆ Step operation ◆◆◆
 "Step operation" executes the program line by line. The operation speed is slow, and the robot stops after each line, so the program and operation position can be confirmed.

- ◆◆◆ Immediately stopping the robot during operation ◆◆◆
- Press the [EMG.STOP] (emergency stop) switch.
 The servo will turn OFF, and the moving robot will immediately stop.
 To resume operation, reset the alarm, turn the servo ON, and start step operation.
 - Release or forcibly press the "enable" switch.
 The servo will turn OFF, and the moving robot will immediately stop.
 To resume operation, lightly press the "enable" switch, and start step operation.
 - Release the [F1] (FWD)key.
 The step execution will be stopped. The servo will not turn OFF.
 To resume operation, press the [F1] (FWD)key.

(5) Correcting the program

■ Correcting the commands

As an example, the joint movement at line No.7 will be changed to linear movement.

(Change 7 Mov PPUT, +20 to 7 Mvs PPUT, +20) ^{Note)}

The diagram illustrates the process of correcting a program command. It shows three stages of the screen display:

- Initial Program Screen:** Shows a program with four lines: 1 Mov pwait, 2 Mov PGET +20, 3 Mvs PGET, and 4 Hclose 1. Line 7 is highlighted with the command '7 Mov PPUT, +20'. Below the screen are control buttons: EDIT, DELETE, 123, INSERT, and CLOSE.
- Function Display Screen:** Reached by pressing the [FUNCTION] key (F2). It shows buttons: FWD, JUMP, 123, BWD, and CLOSE.
- Step Display Screen:** Reached by pressing [7] and [EXE]. It shows 'STEP (7)' and buttons: 7 PQRS and EXE.
- Corrected Program Screen:** Reached by pressing [FUNCTION] again. Line 7 is now '7 Mvs PPUT, +20'. Below the screen are control buttons: EDIT, DELETE, 123, INSERT, and CLOSE.

1) Press the [FUNCTION] key and change the function display. Press the [F2](Jump) key and display the command edit screen.

2) Press the [7], [EXE] key and display the 7th step.

⚠ CAUTION

Note) Upward movement is designated at a position along the Z axis of the TOOL coordinate system, and the direction is designated with the + and - signs. Refer to the section on the TOOL JOG operation in the separate "Installation Manual/ Robot arm setup and maintenance", and confirm the Z axis direction of the TOOL coordinate system. Then, designate the correct sign (direction) that matches the robot being used. Designating the reverse direction could lead to interference with the peripheral devices and damage. Generally (in the default state), the hand retract direction is the "-" sign with the vertical articulate type robot, and the "+" sign is the robot's upward direction with the other robots.

◆◆◆ Displaying a specific line ◆◆◆

Press the [FUNCTION] key, and change the function display, and press the [F2] key. The display changes to the JUNP screen. The specification line can be displayed, if the step number to display in the parenthesis is inputted and the [EXE] key is pressed.

◆◆◆ Displaying the previous and next command step ◆◆◆

Display the four lines on the screen of T/B. For moving the cursor to the front line, the [↑] key is pressed, for moving the cursor to the next line, press the [↓] key, and select.

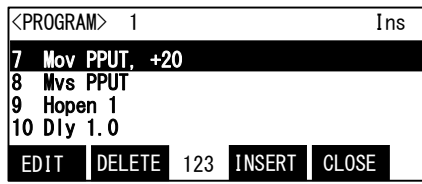

3) Press the [F1] (Edit) key and display command edit screen.

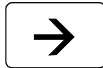
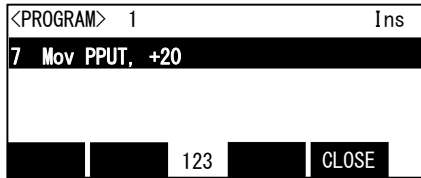

4) Press the [→] key 3 times. Move the cursor to "o."

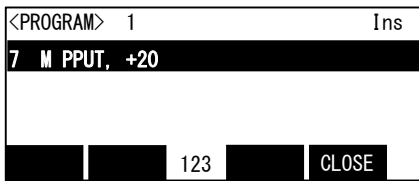

5) Press the [CLEAR] key twice and delete "ov". Leave "M."

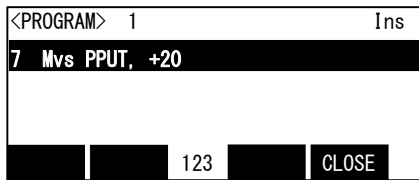

6) Press the [CHARACTER] key and set to the character input mode. Press the [TUV] key 3 times (input "v"), the [→] key, the [PQRS] key 4 times (input "s").

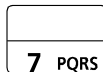
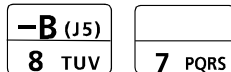

7) Press the [EXE] key and the 7th step is fixed. It returns to the program edit screen of the four-line display.

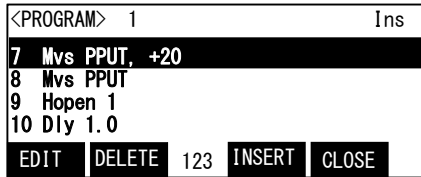

Step No. 7 has been changed to linear movement with the above operation.

◆◆◆ Correcting incorrect numbers ◆◆◆

Press the [CLEAR] key to delete the character, and then input it again. And, if the long pushing [CLEAR] key, all the data in the parenthesis can be deleted. If the cursor is returned by pressing the [←] key, and a character is input, it will be inserted.

◆◆◆ After correcting a program ◆◆◆

After correcting the program, carry out step operation, and confirm that the program has been corrected.

◆◆◆ Inputting characters and space ◆◆◆

Each time the [CHARACTER] key is pressed, the number input mode and the character input mode change. The current input mode is displayed in the center under the screen, and the display of "ABC" shows that the character input mode. The character currently written to the lower right of each key in this state can be inputted. When you continue and input the character in the same key, once press the [→] key and advance the cursor. The space is assigned to the [SP] key.

■ Correcting the taught position

As an example, the wait position (PWAIT) will be corrected.

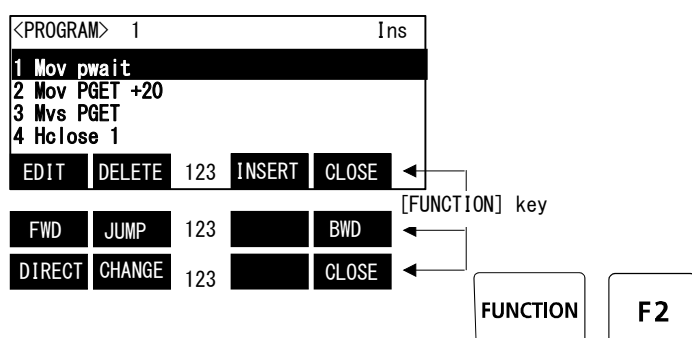
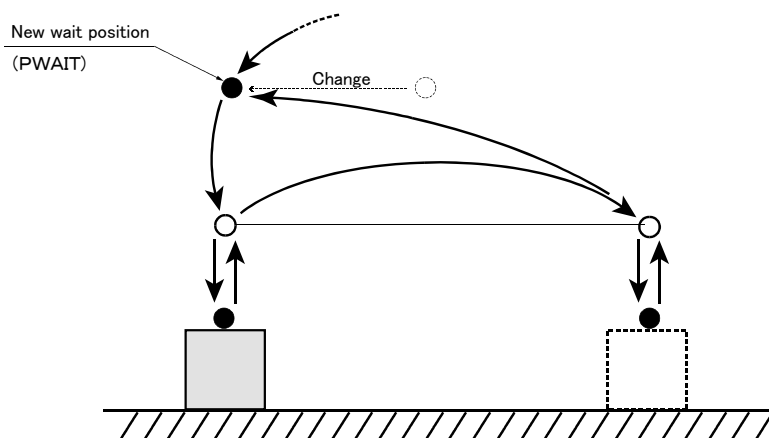

- 1) In the program edit screen, press the [FUNCTION] key twice and change the function display. [F2](change) Press the key and display the position edit screen.

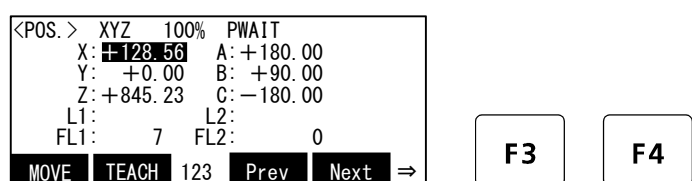

- 2) Press the [F3](Next) or the [F4](Prev) key, and display "PWAIT" on the screen upper right. The current registration coordinate value of the position variable name PWAIT is displayed.

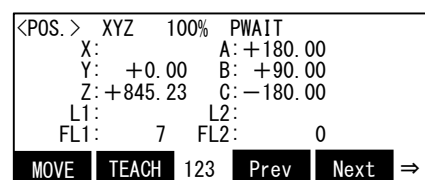

- 3) Move the robot to the new standby position by jog operation.

Refer to [Page 53, "4.4 Jog operation"](#) for details on the jog operation, and section [Page 54, "4.5 Opening and closing the hand"](#) for details on opening and closing the hand.

◆◆◆ Calling out a position variable ◆◆◆

The displayed position variable can be scrolled up or down by pressing the [F3] (Next) or [F4] (Prev) key.

```

<POS.> XYZ 100% PWAIT
X: +123.56 A: +180.00
Y: +0.00 B: +90.00
Z: +845.23 C: -180.00
L1: L2:
FL1: 7 FL2: 0
MOVE TEACH 123 Prev Next =>
    
```

F2

4) Press the [F2] (Teaching) key.
The teaching confirmation screen is displayed.

```

<POS. EDIT> 1
PWAIT
RECORD CURRENT POSITION.
OK?
Yes 123 No
    
```

F1

5) Press the [F1] (Yes) key and register the position.

```

<POS.> XYZ 100% PWAIT
X: +123.56 A: +180.00
Y: +0.00 B: +90.00
Z: +845.23 C: -180.00
L1: L2:
FL1: 7 FL2: 0
MOVE TEACH 123 Prev Next =>
    
```

Correction of the standby position is completed.

◆◆◆ After correcting a program ◆◆◆

After correcting the program, carry out step operation, and confirm that the program has been corrected.

(6) Saving the program

If creation of the program or correction finishes, the program will certainly be saved.

If the [F4 (close)] key is pressed in the command edit screen or the position edit screen, the confirmation message "the program was saved" is displayed and the details of edit are saved.

◆◆◆ Attention about the edit save ◆◆◆

Please keep in mind that the details of edit including teaching data will be canceled if the power supply is shut down with the program edit screen.

(7) Start automatic operation.

Operations are carried out from the <OPERATION> screen opened by selecting <MENU> → <RUN>.

**CAUTION**

The T/B has the operation rights while displaying the <OPERATION> screen. (The T/B's status display lamp [ENABLE] blinks)

Note that operations which require external signal to have operation rights cannot be executed.

The functions which can be executed from the T/B <OPERATION> screen and the operations which can be executed while the <OPERATION> is displayed are shown below.

Operations from <OPERATION> screen (Each function key)

- <1> Selecting a program....."CHOOSE"
- <2> Turning servo ON/OFF....."SV. ON" / "SV. OFF"
(When the controller mode sets "AUTOMATIC", the ENABLE switch does not need to be turned ON.)
- <3> Executing automatic operation....."START"
- <4> Changing operation mode (continuous/cycle)....."CONT./CYCLE"
- <5> Resetting a program....."RESET"

Other key operations

- <1> Changing the movement speed.....[OVRD ↑] / [OVRD ↓] key
Note) When the controller (drive unit) mode is set to "AUTOMATIC", the robot moves at the regular speed. When set to "MANUAL", the robot moves at low speed (to confirm movement). Set the controller (drive unit) to the required mode.
- <2> Turning servo ON.....[SERVO] key
(When the controller mode sets "AUTOMATIC", the ENABLE switch does not need to be turned ON.)
- <3> Resetting the alarm.....[RESET] key

* The robot can be stopped at any time with the [EMG. STOP] switch or [STOP] key.
Operations using the [JOG], [HAND] or [MONITOR] key will be invalid.

The methods for starting automatic operation from the T/B are explained in this section.

- 1) Set the T/B [ENABLE] switch to "DISABLE".

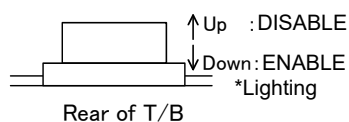

- 2) Set the controller's mode to "AUTOMATIC".
- 3) Press [2] key while the <MENU> screen is displayed. The <RUN> screen appears.

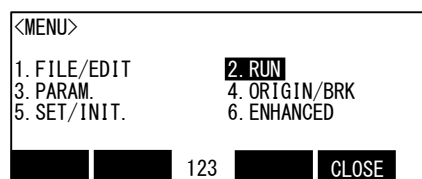

RUN menu selection [2]

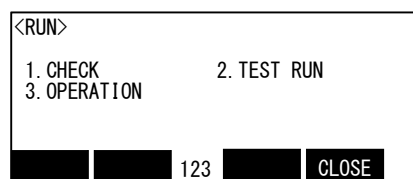

4) Press [3] key while the <RUN> screen is displayed. The <OPERATION> screen appears.

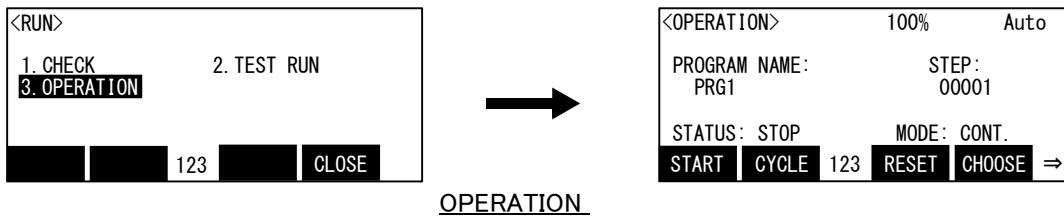

⚠ CAUTION

Before starting automatic operation, always confirm the following items. Starting automatic operation without confirming these items could lead to property damage or physical injury.

- Make sure that there are no operators near the robot.
- Make sure that the safety fence is locked, and operators cannot enter unintentionally.
- Make sure that there are no unnecessary items, such as tools, inside the robot operation range.
- Make sure that the workpiece is correctly placed at the designated position.
- Confirm that the program operates correctly with step operation.

Explanation of <OPERATION> screen

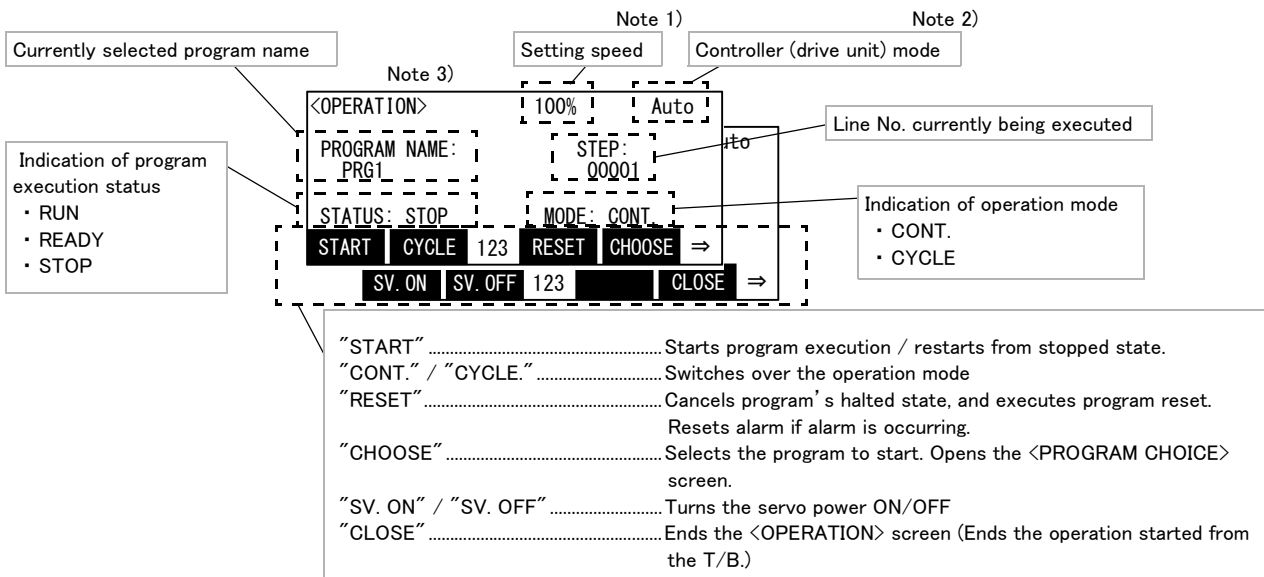

Note 1) If the controller mode is "MANUAL", low speed movement will take place even if the set speed is 100%. (To confirm the movements)

Note 2) When the controller mode is "AUTOMATIC", the T/B's status display lamp [ENABLE] will blink to indicate that the T/B is enabled. The T/B is disabled when the <OPERATION> screen is ended.

Note 3) The [JOG], [HAND] and [MONITOR] keys are disabled while the <OPERATION> screen is opened.

5) Press the function key [F4] assigned to "CHOOSE" while the <OPERATION> screen is displayed. The <PROGRAM CHOICE> screen opens.

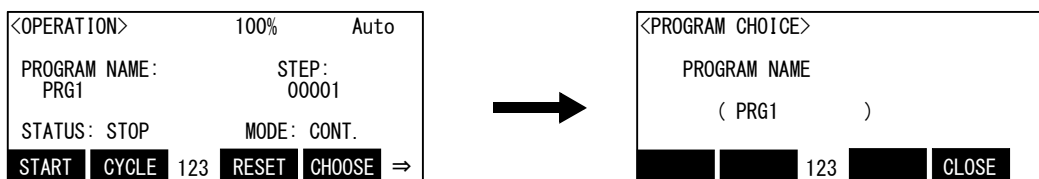

Program selection [F4]

Name of the currently selected program is displayed.

- 6) Enter the name of the program into the Program Name brackets, and press the [EXE] key.
The program will be newly selected, and the display will return to the <OPERATION> screen.

<PROGRAM CHOICE>			
PROGRAM NAME			
(PRG2)			
123	CLOSE		



<OPERATION>	100%	Auto		
PROGRAM NAME:	PRG2	STEP:	00001	
STATUS: STOP		MODE: CONT.		
START	CYCLE	123	RESET	CHOOSE =>

Enter the program name and press [EXE] key

The figure shows an example of changing program name to "PRG2".

- 7) Press the function key [F1] assigned to "SV. ON" to turn the servo power ON. (Press the [FUNCTION] key if the "SV. ON" function is not displayed.)

<OPERATION>	100%	Auto		
PROGRAM NAME:	PRG2	STEP:	00001	
STATUS: STOP		MODE: CONT.		
SV. ON	SV. OFF	123	CLOSE	=>



<OPERATION>	100%	Auto		
PROGRAM NAME:	PRG2	STEP:	00001	
STATUS: STOP		MODE: CONT.		
SV. ON	SV. OFF	123	CLOSE	=>

Servo ON [F1]



CAUTION

Before starting automatic operation, always confirm that the target program No. is selected.



CAUTION

Take special care to the robot movements during automatic operation. If any abnormality occurs, press the [EMG. STOP] switch and immediately stop the robot.



CAUTION

When beginning automatic operation, move at low speed at first, and you should gather speed slowly with being careful of interference with peripheral equipment. The movement speed can be changed with the [OVRD ↑] and [OVRD ↓] keys on the T/B.

- 8) Press the function key [F1] assigned to "START" to open the CHECK screen.

<OPERATION>	100%	Auto		
PROGRAM NAME:	PRG2	STEP:	00001	
STATUS: STOP		MODE: CONT.		
START	CYCLE	123	RESET	CHOOSE =>



<STARTING PROGRAM>				
PRG2				
START THE PROGRAM.				
OK?				
Yes	123	No		

Start [F1]

- 9) Press the function key [F1] assigned to "YES". Automatic operation of the currently selected program will start.

The screen will return to the <OPERATION> screen.

<STARTING PROGRAM>				
PRG2				
START THE PROGRAM.				
OK?				
Yes	123	No		



<OPERATION>	100%	Auto		
PROGRAM NAME:	PRG2	STEP:	00001	
STATUS: RUN		MODE: CONT.		
START	CYCLE	123	RESET	CHOOSE =>

Yes [F1]

10) The operation mode follows the mode displayed on the screen.
Change the mode if necessary.

<OPERATION>	100%	Auto
PROGRAM NAME: PRG2	STEP: 00001	
STATUS: RUN	MODE: CONT.	
START	CYCLE 123	RESET CHOOSE ⇒



<OPERATION>	100%	Auto
PROGRAM NAME: PRG2	STEP: 00001	
STATUS: RUN	MODE: CYCLE	
START	CONT. 123	RESET CHOOSE ⇒

Change operation mode [F2]

The figure shows an example of changing from "CONT." to "CYCLE".

The starting of automatic operation from the T/B is completed.

5 Maintenance and Inspection

The maintenance and inspection procedures to be carried out to use the robot for a long time without trouble are described in this chapter. The types and replacement methods of consumable parts are also explained.

5.1 Maintenance and inspection interval

Maintenance and inspection are divided into the inspections carried out daily, and the periodic inspections carry out at set intervals. Always carry these out to prevent unforeseen trouble, to maintain the product for a long time, and to secure safety.

(1) Inspection schedule

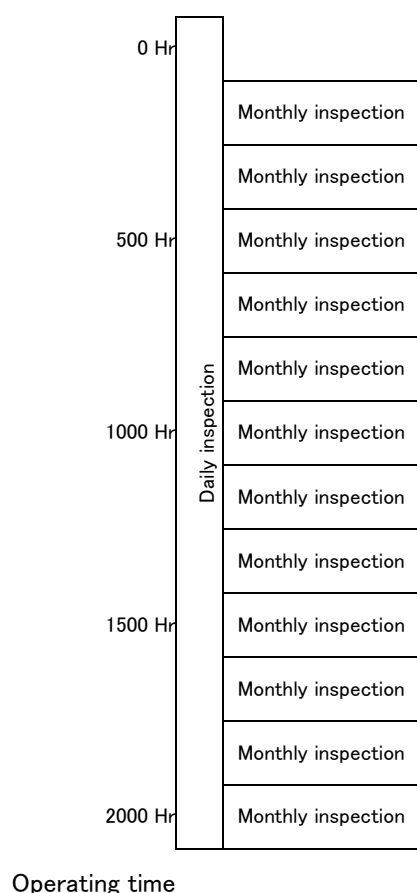

<Guideline for inspection period>

For one shift

$8 \text{ Hr/day} \times 20 \text{ days/month} \times 12 \text{ months} = \text{approx. } 1800 \text{ Hr}$

$10 \text{ Hr/day} \times 20 \text{ days/month} \times 12 \text{ months} = \text{approx. } 2400 \text{ Hr}$

For two shifts

$15 \text{ Hr/day} \times 20 \text{ days/month} \times 12 \text{ months} = \text{approx. } 3600 \text{ Hr}$

[Caution] According to the schedule on the above, when using the double shift, you should make the inspections at half the regular intervals.

Fig. 5-1 : Inspection schedule

5.2 Inspection items

The controller inspection items are shown below.

Refer to section "Maintenance and Inspection" in the separate manual "Robot arm setup and maintenance", and inspect the robot arm at the same time.

5.2.1 Daily inspection items

Carry out daily inspections following the procedures given in [Table 5-1](#).

Table 5-1 : Daily inspection items (details)

Procedure	Inspection items (details)	Remedies
Before turning the power ON (Check the following inspection items before turning the power ON.)		
1	Is the power cable securely connected? (Visual)	Securely connect.
2	Are the machine cables between the robot arm and controller securely connected? (Visual)	Securely connect.
3	Is the controller cover cracked, has any foreign matter adhered, or is there any interference?	Replace with a new part, or take remedial measures.
After turning the power ON (Turn the power ON while monitoring the robot.)		
1	Is there any abnormal movement or noise when the power was turned ON?	Refer to the Troubleshooting section and remedy.
During operation (Try moving with an original program.)		
1	Check that the operation point is not deviated. If deviated, check the following items. 1) Are any of the installation bolts loose? 2) Are the bolts at the hand installation section loose? 3) Is the position of the jigs, other than the robot, deviated? 4) If the positional deviation cannot be eliminated, refer to "Troubleshooting", and remedy.	Refer to the Troubleshooting section and remedy.
2	Is there any abnormal movement or noise? (Visual)	Refer to the Troubleshooting section and remedy.

5.2.2 Periodic inspections

Carry out periodic inspections following the procedures given in [Table 5-2](#).

Table 5-2 : Periodic inspection items (details)

Procedure	Inspection items (details)	Remedies
Monthly inspection items		
1	Are any of the connector fixing screws or terminal block terminal screws loose?	Securely tighten the screws.
2	Is the controller filter dirty? (Visual)	Clean or replace with a new part. Inspect, clean and replace the filter by refer to Page 77 , "5.3.2 The check of the filter, cleaning, exchange."

5.3 Maintenance and inspection procedures

The procedures for carrying out periodic maintenance and inspection are described below. Thoroughly comprehend the procedures, and follow the instructions. This work can be commissioned to the Mitsubishi Service Dept. for a fee. (Never disassemble, etc., any of the parts not described in this section.)

The maintenance parts required for the maintenance and inspection are shown in [Page 78, "5.4 Maintenance parts"](#). Contact your dealer for these parts when required.

5.3.1 Replacing the battery (CR800-Q controller only)

In the CR800-Q controller, while power of controller is turned off, the programs must be saved by the backup battery. The robot arm also uses backup batteries to save the position data of an encoder. The batteries are installed when the robot is shipped from the factory, but as these are consumable parts, they must be replaced periodically by the customer.

The guideline for replacing the lithium battery is one year, but this will differ according to the robot's usage state. There are the kind of the errors about the battery shown in [Table 5-3](#). If error 7500 occurs, please exchange the batteries of the robot arm and the robot CPU unit (CR800-Q controller only).

Table 5-3 : The error about the battery

Error number	Description	Measure
7510	Encoder battery voltage low	Replace the battery as soon as possible.
7500	No encoder battery voltage	
112n ^{Note1)}	Encoder ABS position data lost	The backup data cannot be guaranteed if this error occurs.
7451 ^{Note2)}	Robot CPU unit battery voltage low	Replace the battery as soon as possible.
7450 ^{Note2)}	No robot CPU unit battery voltage	The backup data cannot be guaranteed if this error occurs.

Note1) "n" indicates the axis number

Note2) This error occurs in CR800-Q controller only.

The method of replacing the battery of the CR800-Q controller is shown below.

Refer to the separate "ROBOT ARM SETUP & MAINTENANCE" about robot arm's battery.

About the purchase of the battery, refers to [Page 78, "5.4 Maintenance parts"](#).

CAUTION

If error No. 7500 or 112n occurs, the program data and other data in the controller is lost and it becomes necessary to load the data again.

CAUTION

If error 7450 occurs, the program data and other data in the controller is lost and it becomes necessary to load the data such as program and origin data again.

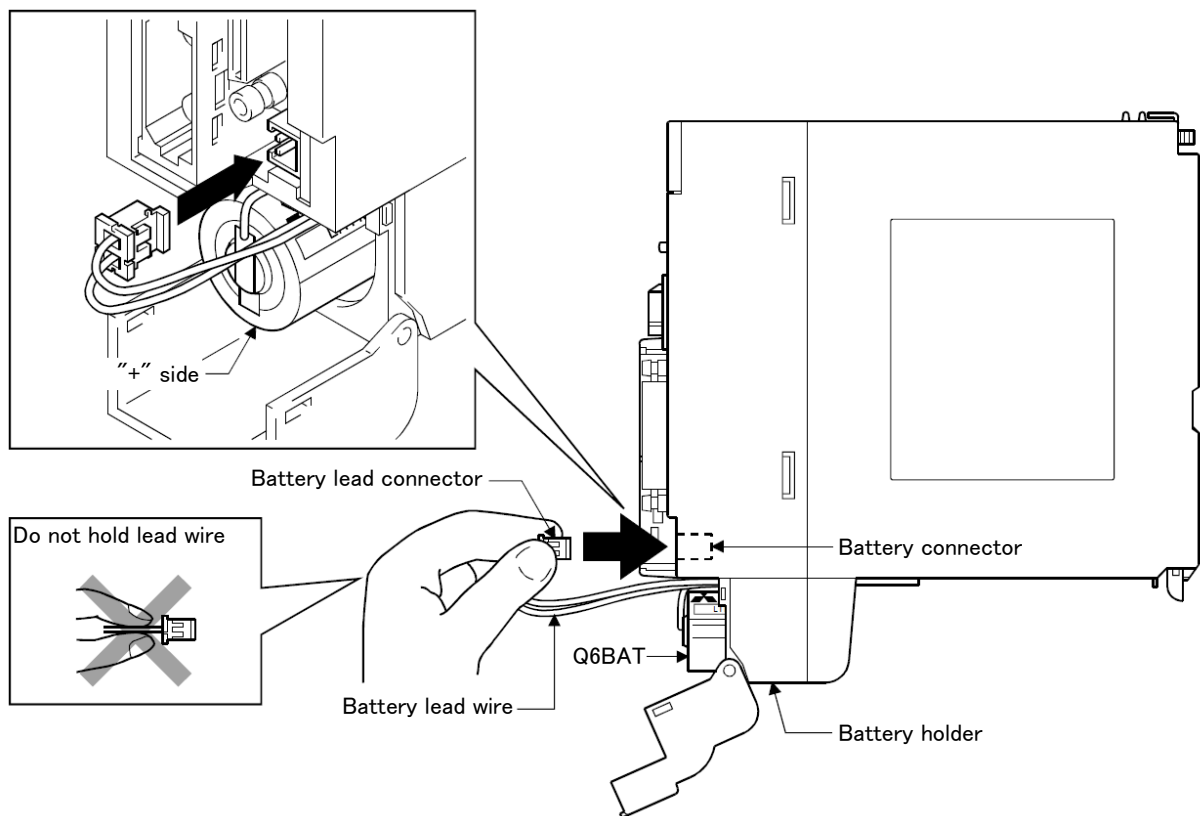

Fig. 5-2 : Exchange of the battery

- 1) Turn on the robot CPU system power supply for 10 minutes or longer.
- 2) Perform a full backup using RT ToolBox3 (option).
- 3) Turn off the robot CPU system power supply.
- 4) Disconnect the lead connector from the battery connector. Remove the old battery from its holder.
- 5) Install a new battery into the holder in the correct direction. Connect the lead connector to the connector (BATTERY). Complete the work within 3 minutes after removing the old battery.
- 6) Turn on the robot CPU system power supply.

[Caution] If the old battery is replaced because it has been used up, it is necessary to operate the robot type resetting. Refer to the separate "Detailed Explanation of Functions and Operations" and operate the robot type resetting.

This completes the replacement of the battery.

5.3.2 The check of the filter, cleaning, exchange.

The filter is installed in the controller.

The following shows the procedure for inspecting, cleaning and replacing the filter:

- 1) Loosen the M4 x 6 screws and remove the filter cover from the front of the controller. Remove the claw on the left side of the filter cover as it is inserted in the front face of the controller.
- 2) Remove the filter from the filter cover and remove dust and other dirt that has built up on it.
* If the filter is particularly dirty then wash it in water and detergent and then dry fully before re-fixing. In the event that the surface of the washed filter has become fluffy, please replace it with a new filter.
- 3) Attach the cleaned or new filter to the controller, and install the filter cover to controller with the M4 x 6 screw.

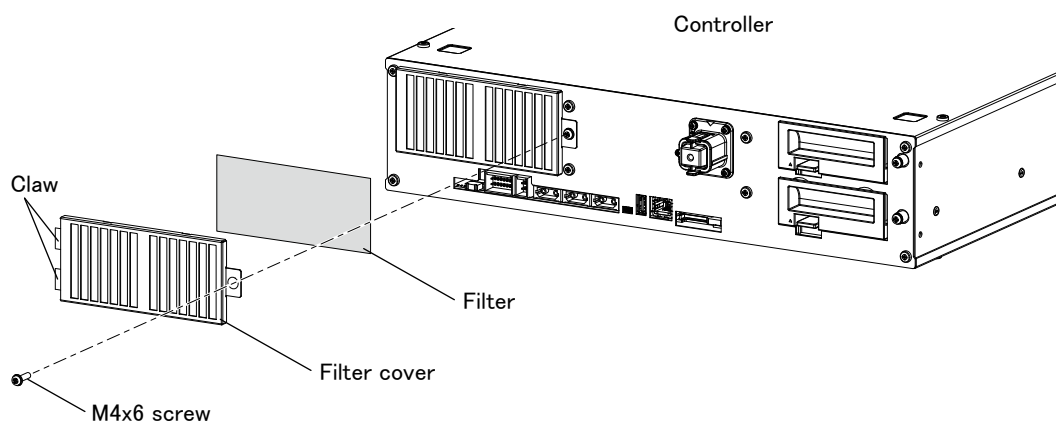

Fig. 5-3 : Cleaning, exchanging the filter

The inspection, cleaning and replace of the filter for the controller is completed.

5.4 Maintenance parts

The consumable parts that must be replaced periodically are shown in [Table 5-4](#), and spare parts that may be required during repairs are shown in [Table 5-5](#). Purchase these parts from the dealer when required. Some Mitsubishi-designated parts differ from the maker's standard parts. Thus, confirm the part name, robot arm and controller serial No. and purchase the parts from the dealer.

Table 5-4 : Controller consumable parts list

No.	Part name	Type ^{Note1)}	Qty.	Usage section	Maker
1	Filter	BKOFA0773H42	1	Inside the filter cover	Mitsubishi Electric Co.
2	Lithium battery	Q6BAT	1	Robot CPU unit: For Q172DSRCPU (CR800-Q controller only)	Mitsubishi Electric Co.

Note1) Confirm the robot arm serial No., and contact the dealer or service branch of Mitsubishi Electric Co., for the type.

Table 5-5 : Controller spare parts list

No.	Part name	Type ^{Note1)}	Qty.	Usage section	Maker
1	1.6A fuse	LM16	1	HAND FUSE (front of the controller)	Mitsubishi Electric Co.

Note1) Confirm the robot arm serial No., and contact the dealer or service branch of Mitsubishi Electric Co., for the type.

MITSUBISHI ELECTRIC CORPORATION

HEAD OFFICE: TOKYO BUILDING, 2-7-3, MARUNOUCHI, CHIYODA-KU, TOKYO 100-8310, JAPAN
NAGOYA WORKS: 5-1-14, YADA-MINAMI, HIGASHI-KU NAGOYA 461-8670, JAPAN

Authorised representative:

Mitsubishi Electric Europe B.V. FA - European Business Group
Mitsubishi-Electric-Platz 1, D-40882 Ratingen, Germany
Tel: +49(0)2102-4860